

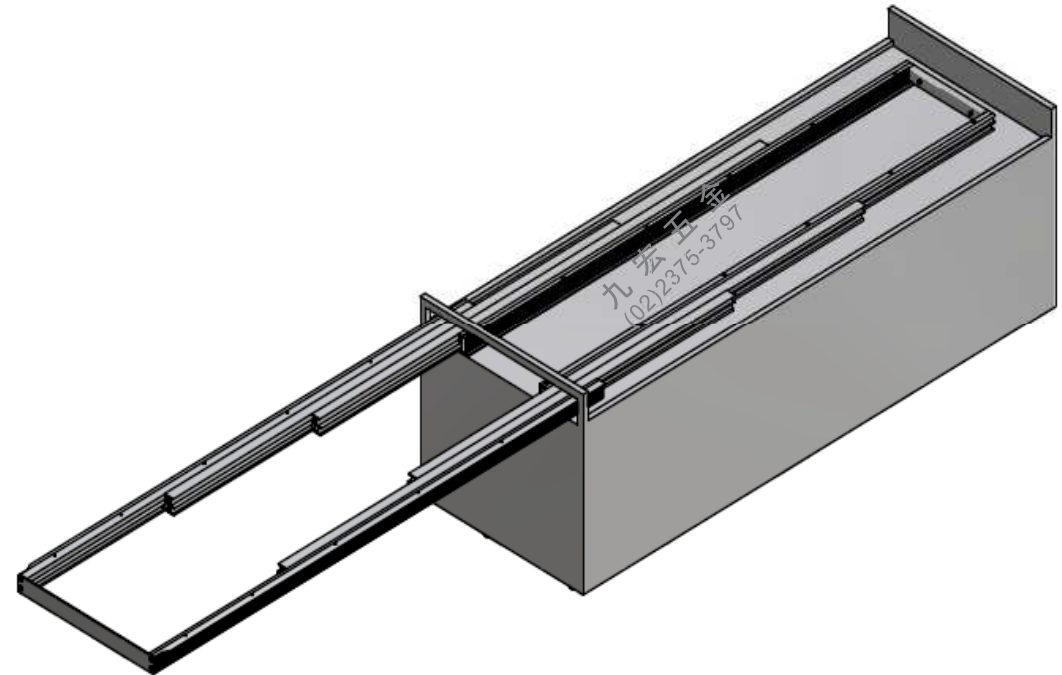

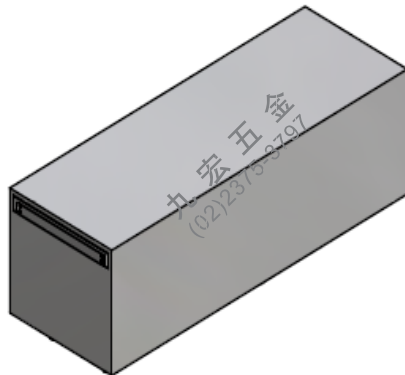

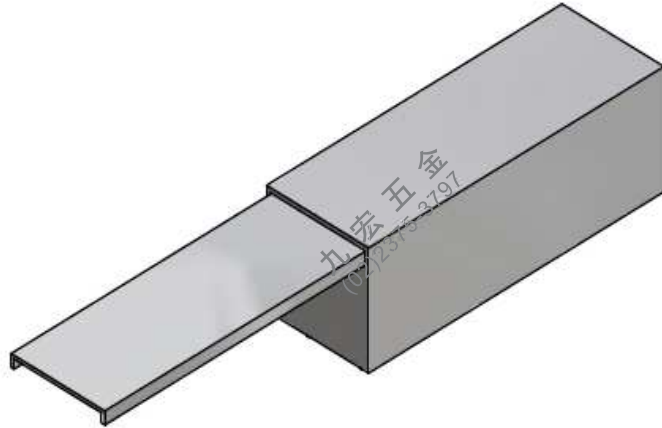







TECHNICAL DRAWING
MOUNTING INSTRUCTION
DESSINS TECHNIQUES
INSTRUCTIONS DE MONTAGE

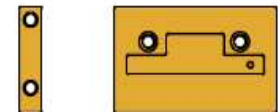

THE PACKAGING INCLUDES: L'EMBALLAGE COMPREND :

ACCESSORIES BAG INCLUDING: LE SAC DE QUINCAILLERIE COMPREND :

- A -  (2 x) M6 x 16
- B -  (4 x) M6 x 30
- C -  (4 x) M6 x 10
- D -  (24 x) M6 x 60
- E -  (4 x) M6 x 70
- F -  (4 x) Ø8 x 12 M6 BRASS BUSHINGS / BAGUE EN LAITON
- G -  (12 x) Ø20 x 3.2 mm BI-ADHESIVE FELT/ FEUTRE BI-ADHÉSIF
- H -  (2 x) NYLON JOINTS / JOINTS EN NYLON
- I -  (2 x) ZAMACH JOINTS/ JOINTS EN ZAMAK
- J -  (1 x) #5 ALLEN KEY / CLE ALLEN
- K -  (1 x) #4 ALLEN KEY / CLE ALLEN
- L -  (1 x) #2.5 ALLEN KEY/ CLE ALLEN

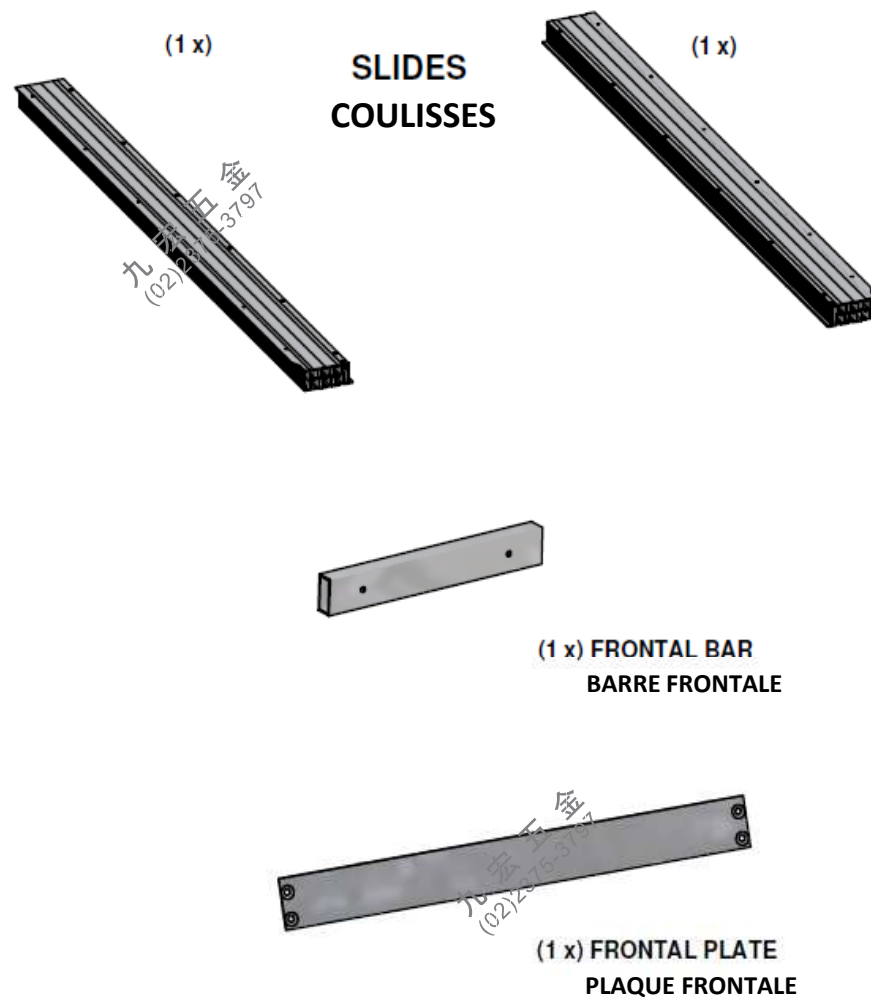

CABINET SUGGESTED DIMENSIONS DIMENSIONS DE CAISSON SUGGÉRÉ

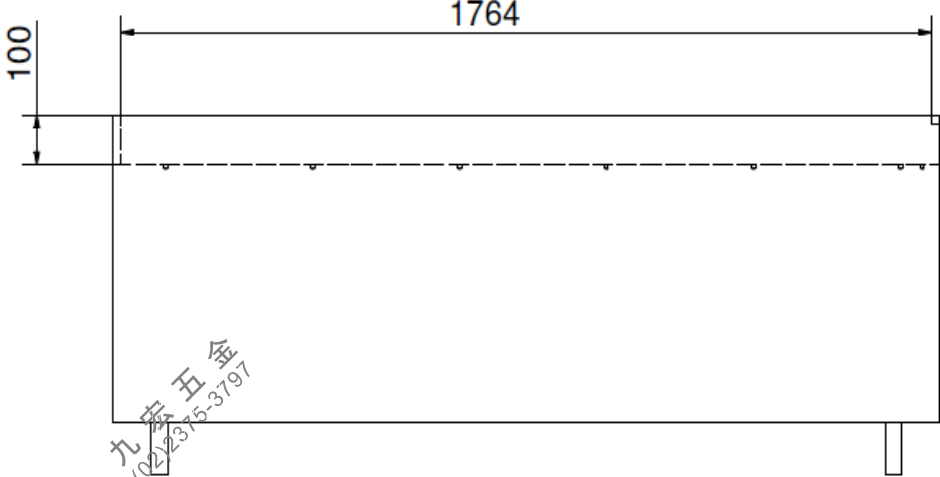
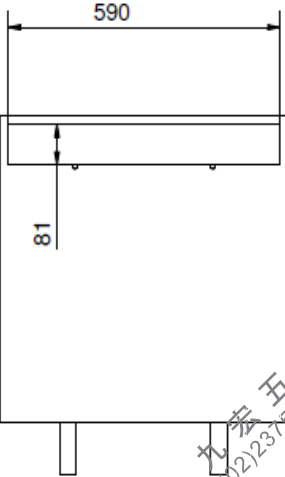

LENGTH / LONGUEUR : 1764mm MIN.
HEIGHT / HAUTEUR : 100mm MIN.
WIDTH / LARGEUR : 590mm MIN.
TABLE TOP COMPLETE EXTENSION: 1600 mm
EXTENSION TOTALE DES PANNEAUX DE TABLE : 1600mm

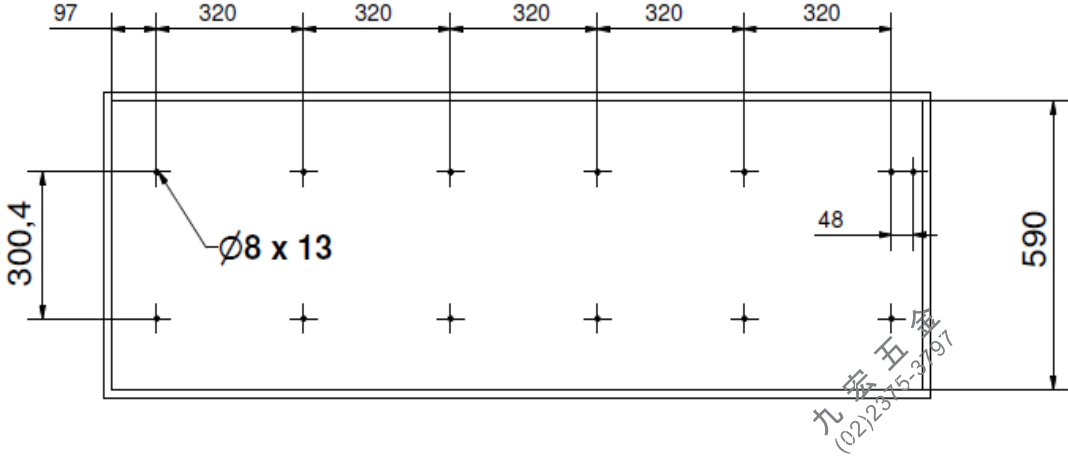
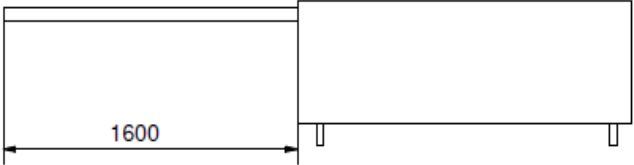

BUSHING MOUNTING ON CABINET
MONTAGE DES BAGUES SUR LE CAISSON

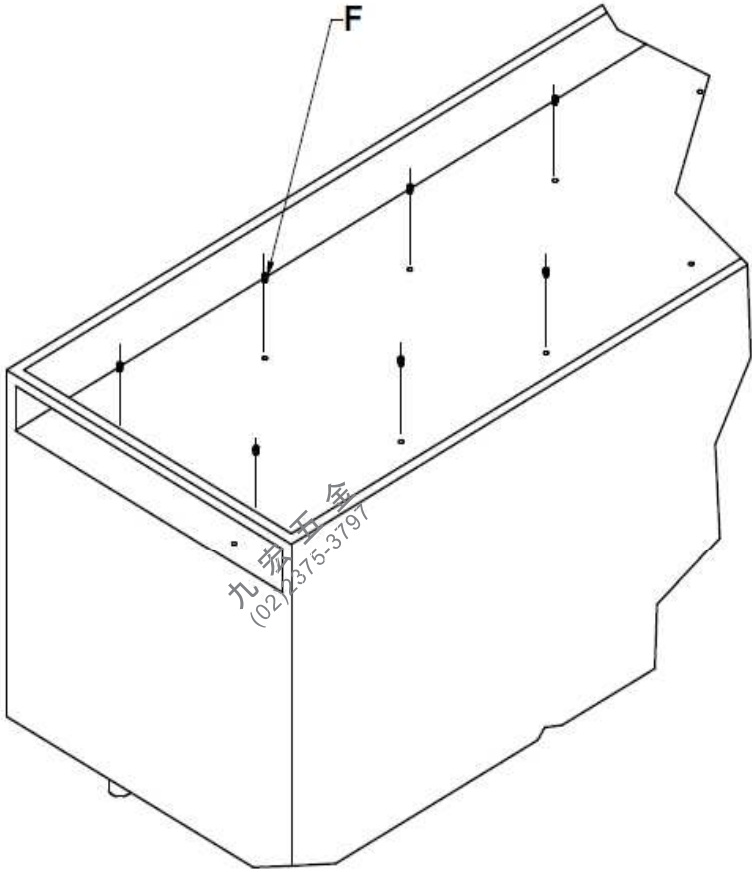
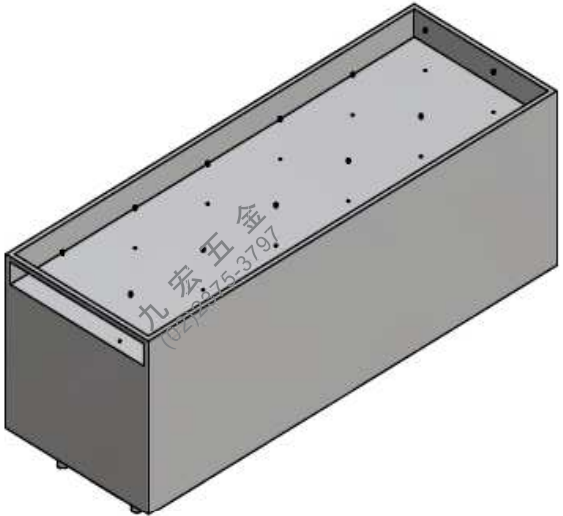

F-  x 12

ADHESIVE FELTS MOUNTING MONTAGE DES FEUTRES ADHÉSIFS

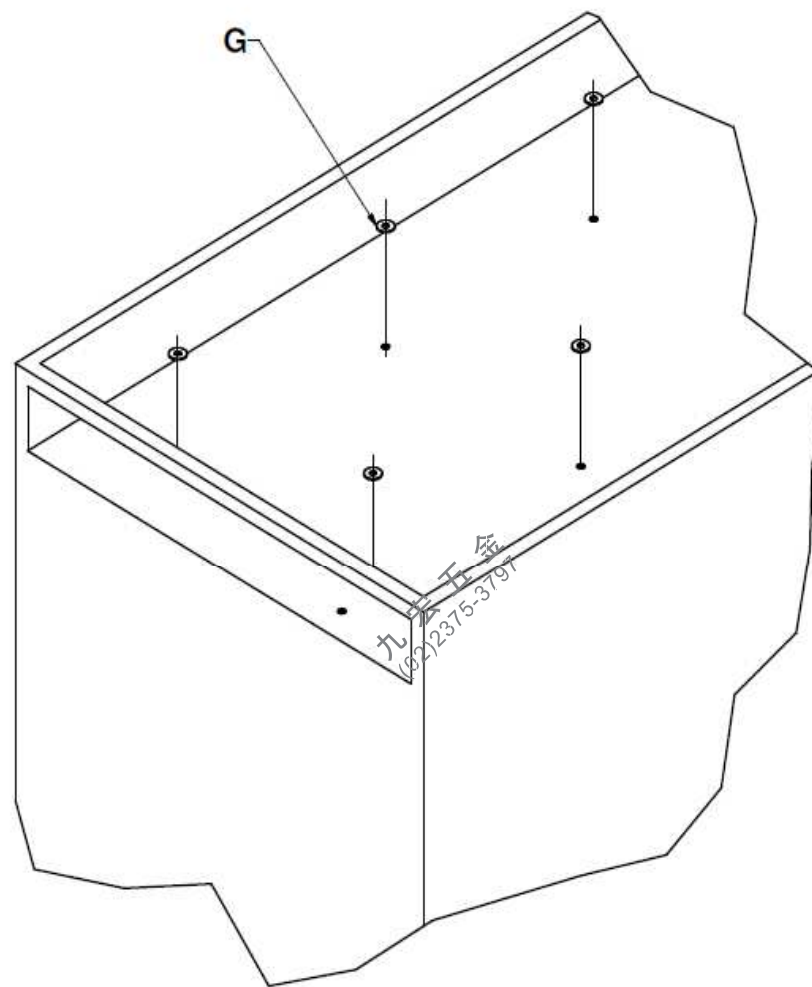
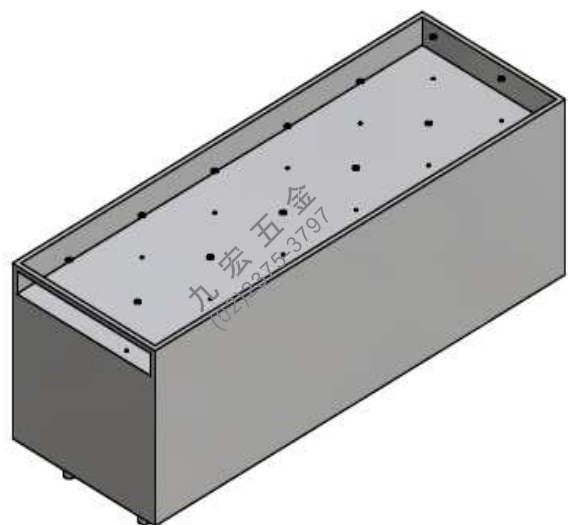

G -  x 12

PLASTIC JOINTS MOUNTING MONTAGE DES JOINTS EN PLASTIQUE

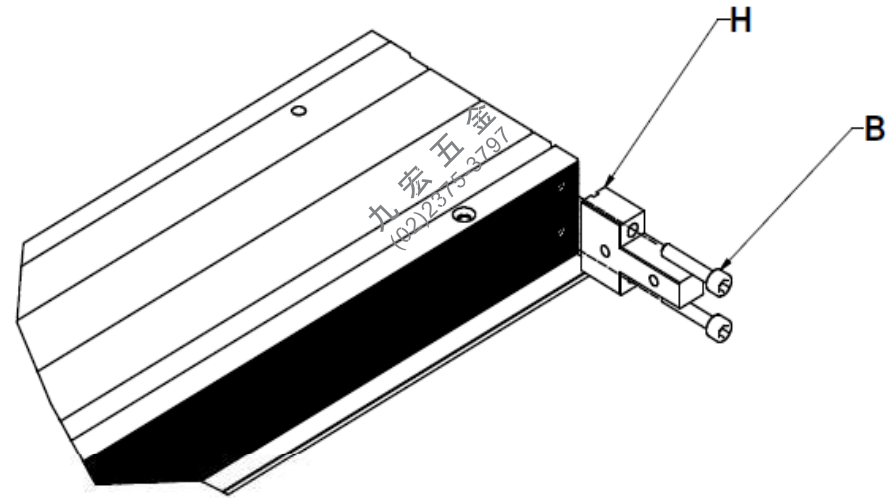

ONE JOINT ON EACH SLIDE
UN JOINT DE CHAQUE CÔTÉ

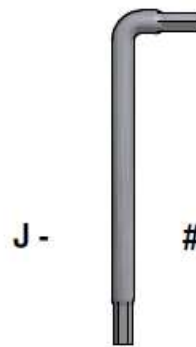

J -

#5 ALLEN KEY
CLÉ ALLEN

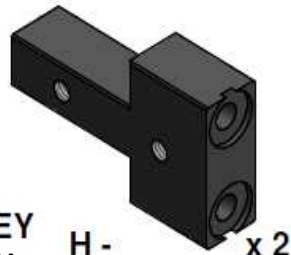

H -

x 2

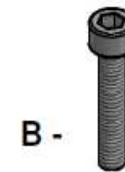

B -

M6 x 30 (x 4)

FRONTAL BAR MOUNTING MONTAGE DE LA BARRE FRONTALE

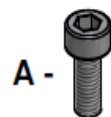
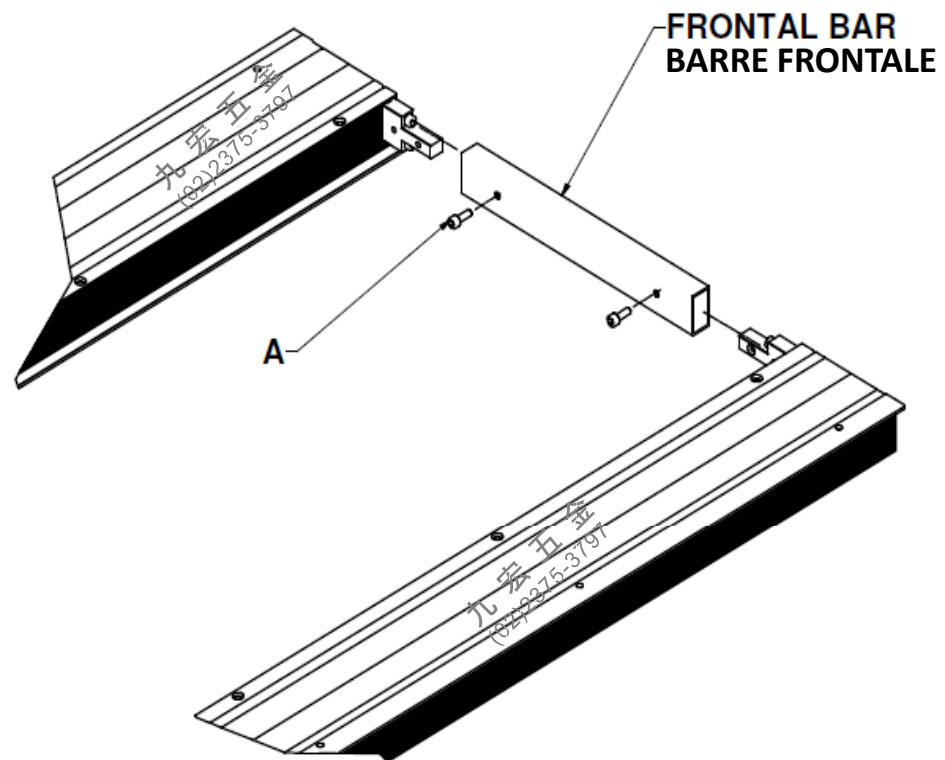

A - M6x16 (x2)



J - #5 ALLEN KEY / CLÉ ALLEN

ZAMAK JOINTS MOUNTING MONTAGE DES JOINTS EN ZAMAK

INSERT THE ZAMAK JOINTS (THREADED SIDE IN THE INSIDE OF THE SLIDES) AND FIX IT WITH THE INDICATED SCREWS.

INSÉREZ LES JOINTS EN ZAMAK (LES CÔTÉS FILETÉS À L'INTÉRIEUR DE LA COULISSE) ET FIXEZ À L'AIDE DES VIS INDIQUÉES.

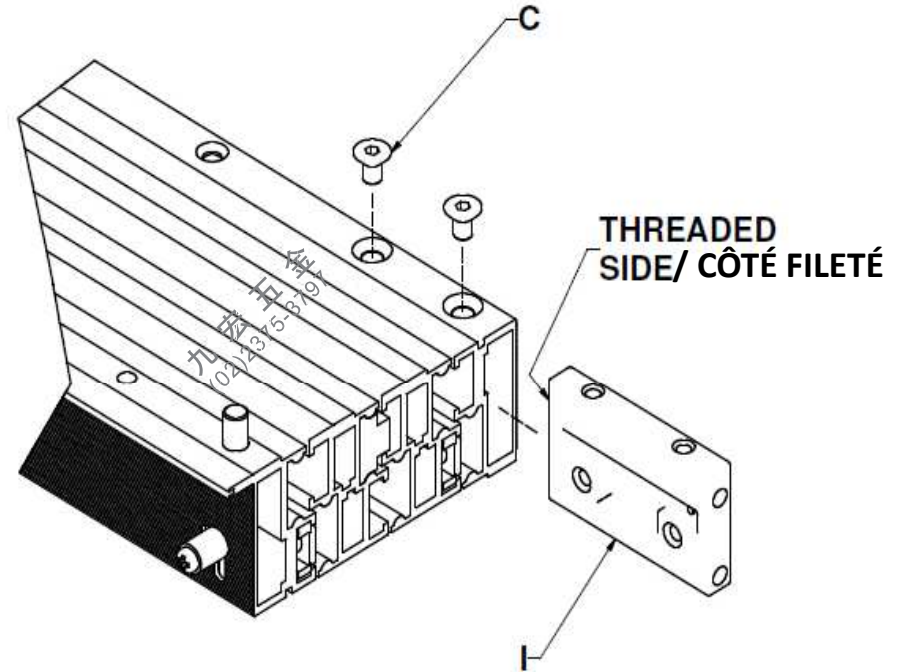

THREADED SIDE
CÔTÉ FILETÉ

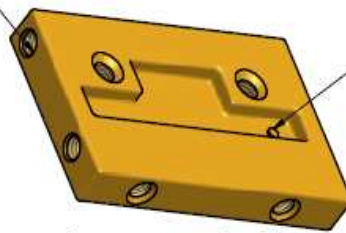

I- (x2)

DOT / POINTE

C-  M6 x 10 (x4)

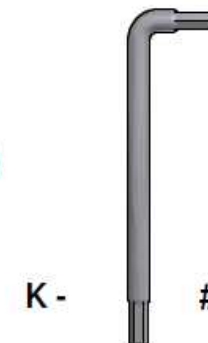

K- #4 ALLEN KEY
CLÉ ALLEN

SLIDES MOUNTING ON THE CABINET MONTAGE DES COULISSES SUR LE CAISSON

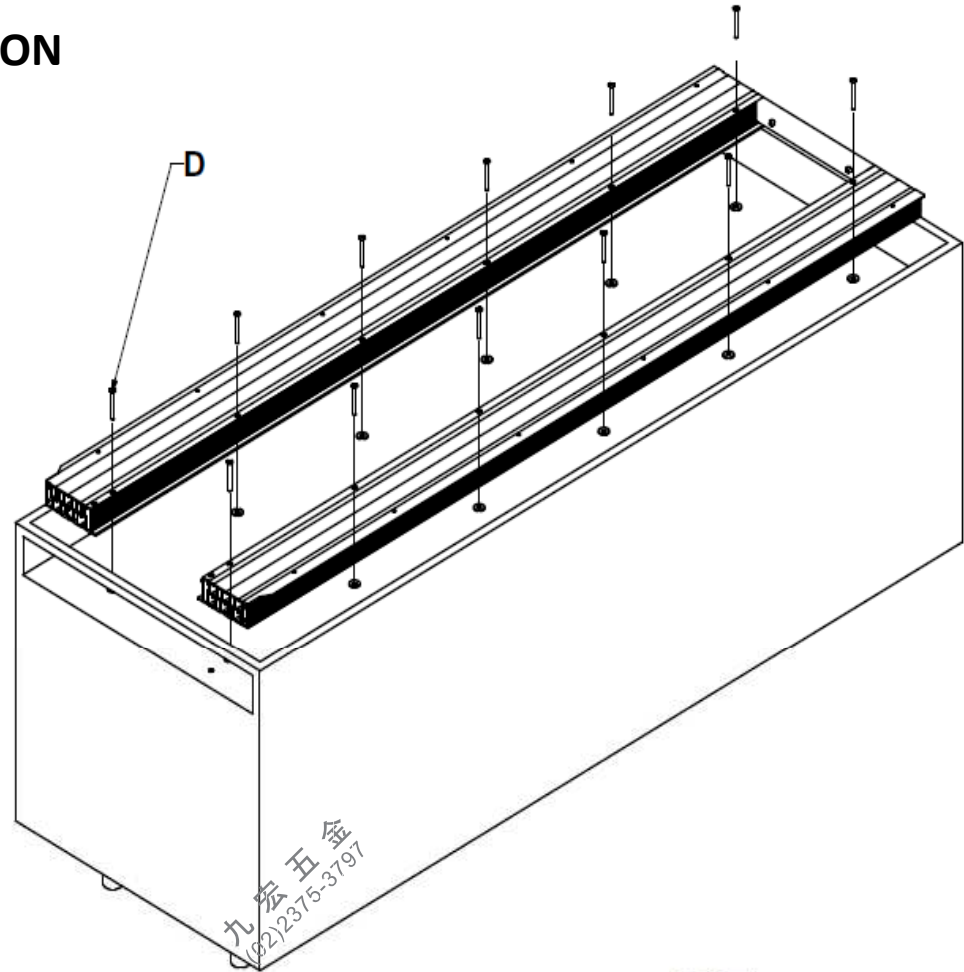
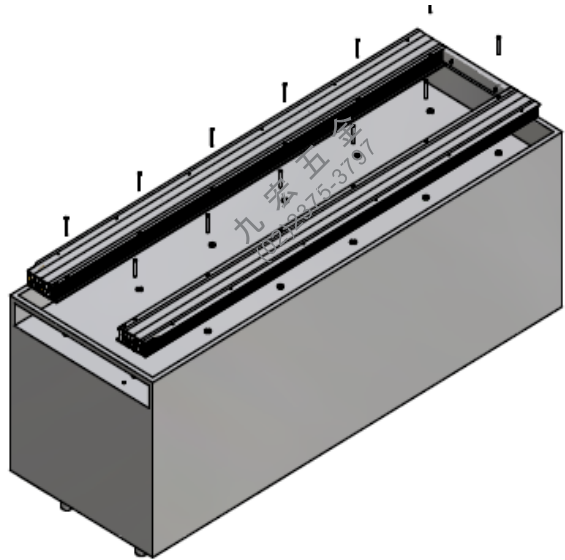

D - M6 x 60 (x 12)



K - #4 ALLEN KEY
CLÉ ALLEN

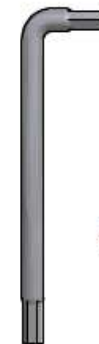

TABLE TOP DRILLING PERÇAGE DU PANNEAU DE TABLE

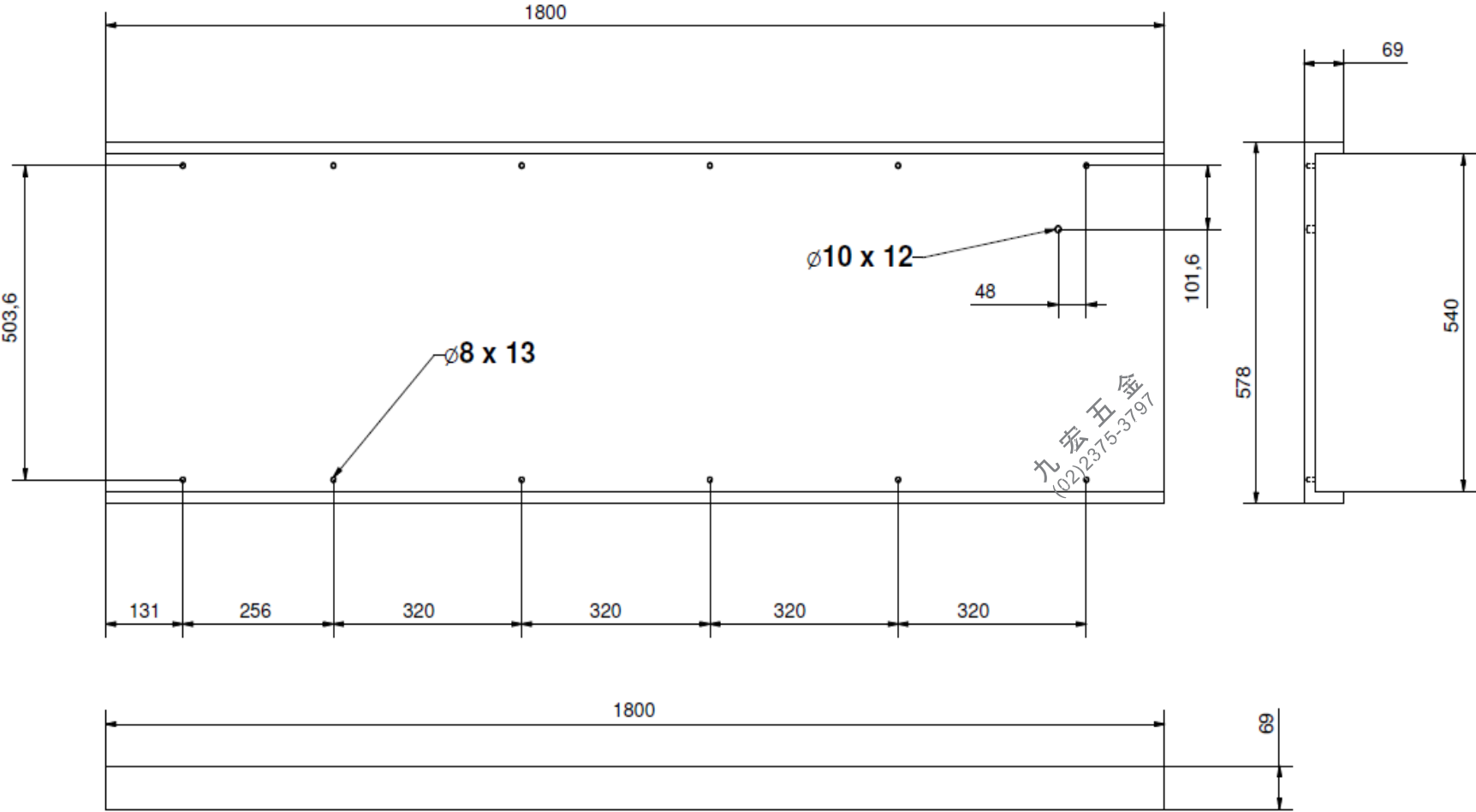
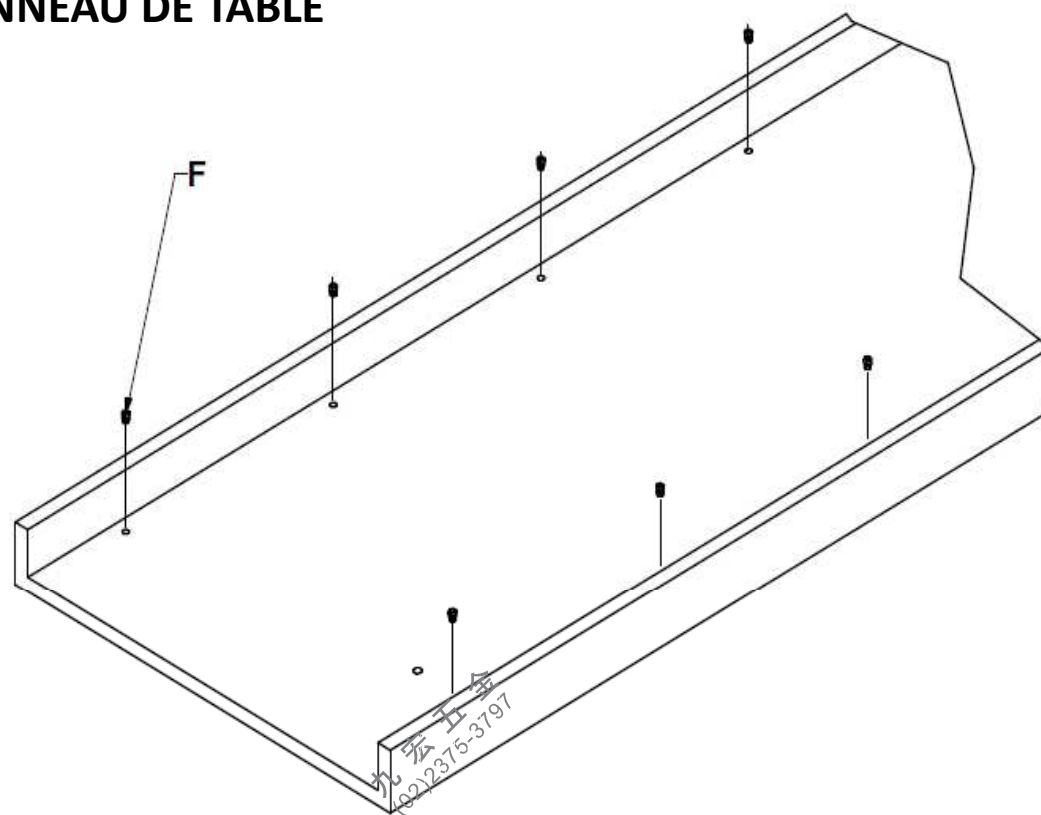
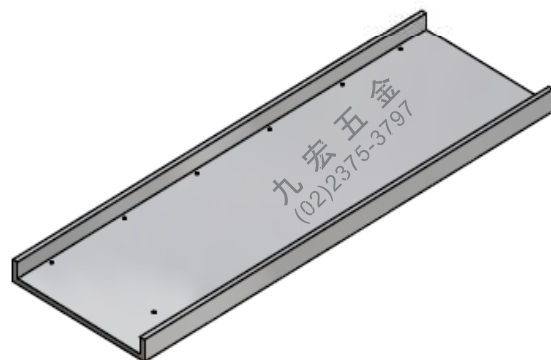
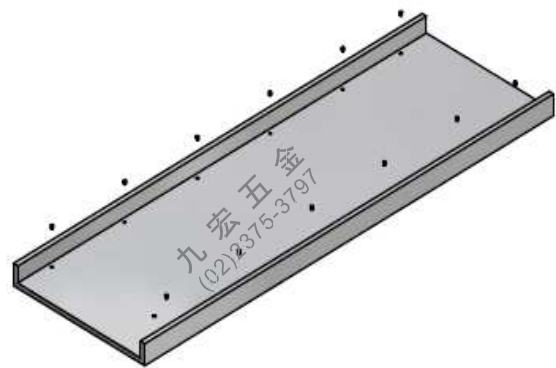

TABLE TOP BUSHING MOUNTING MONTAGE DES BAGUES SUR LE PANNEAU DE TABLE



F -  x12

EXTERNAL SLIDES MONTING UNDER THE TABLE TOP MONTAGE DE LA COULISSE EXTERNE SOUS LE PANNEAU DE TABLE

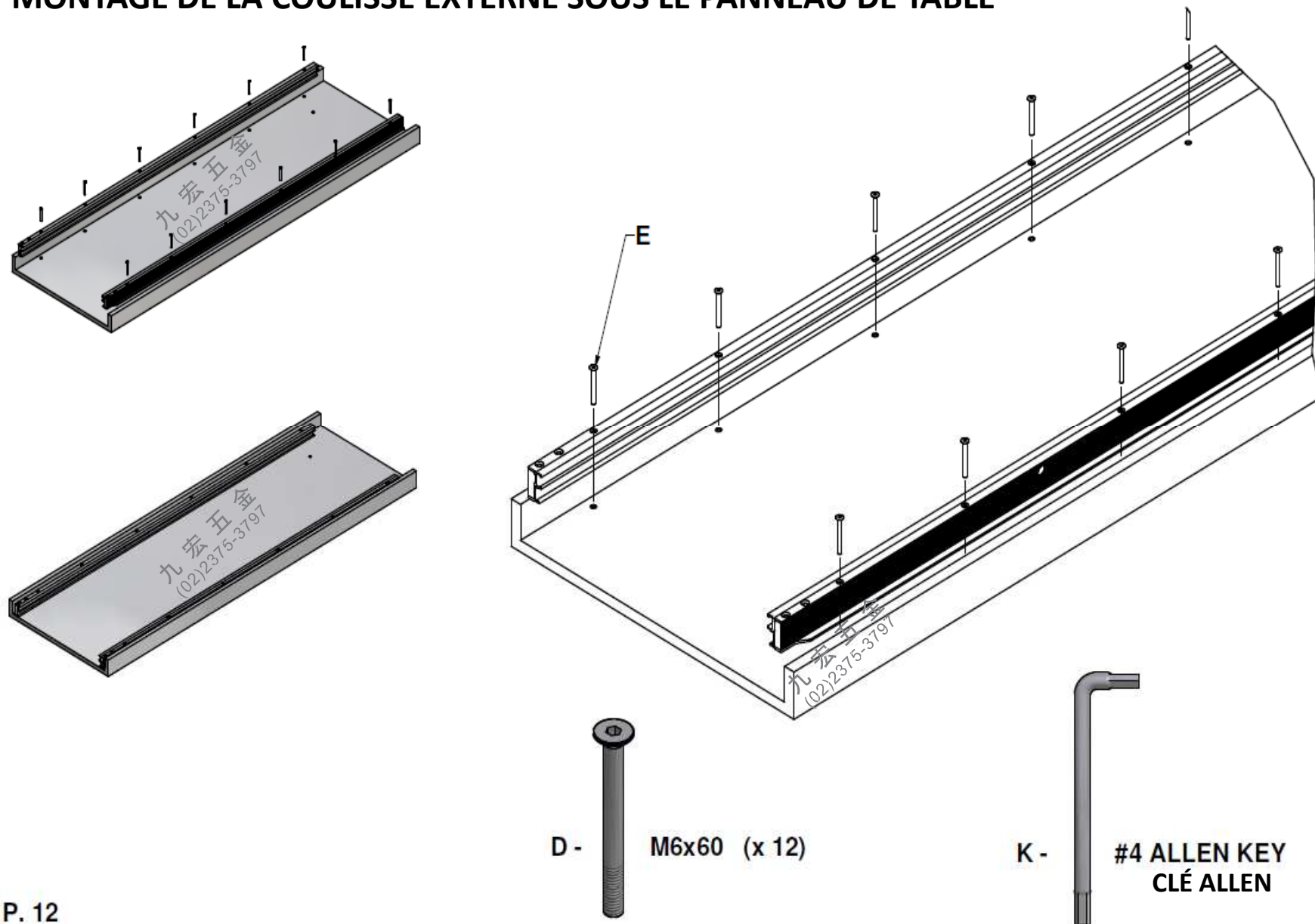
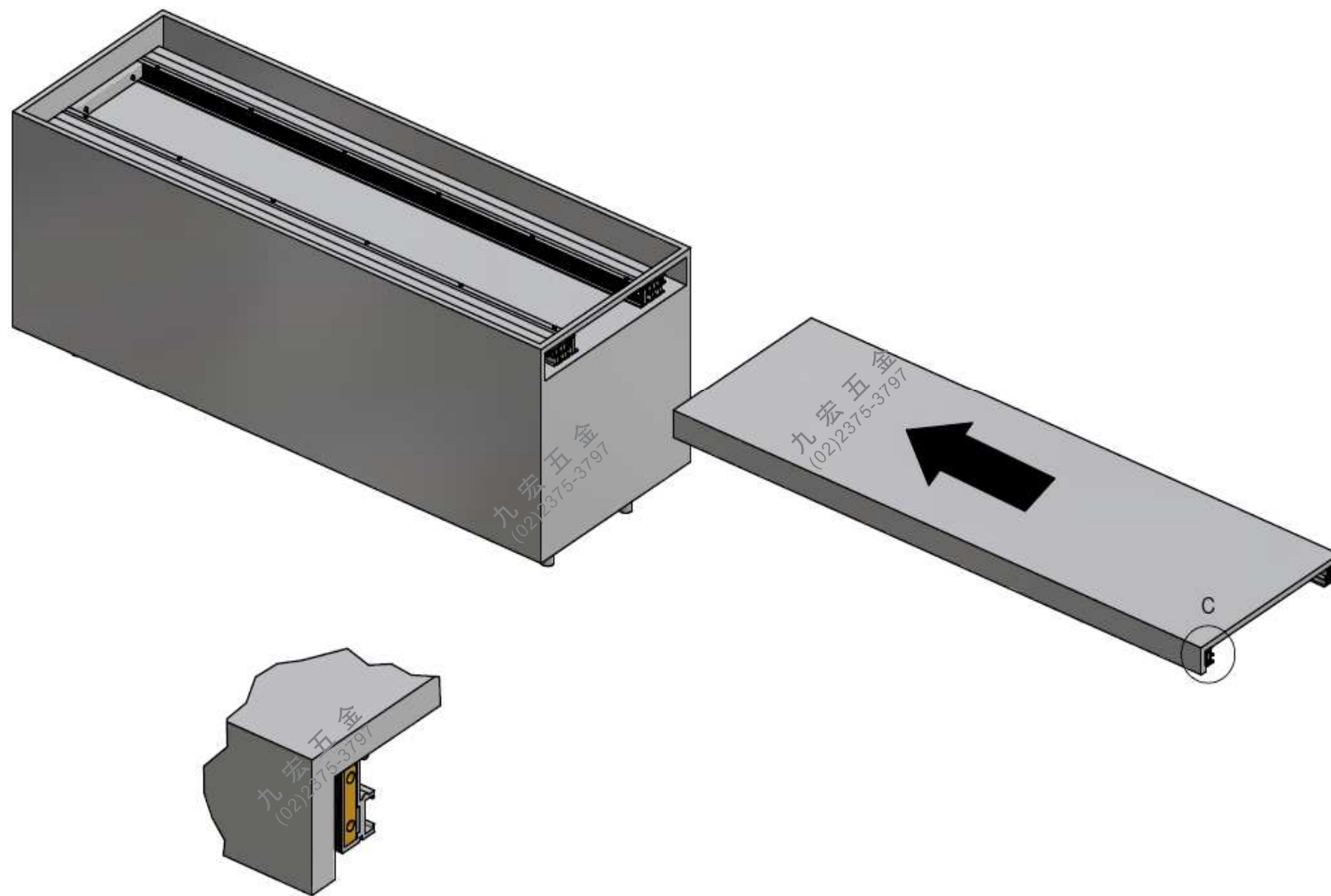
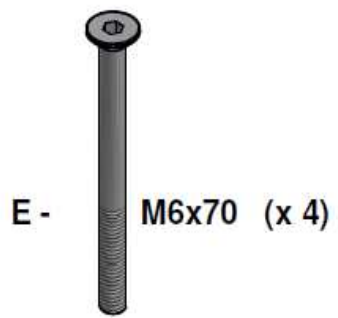
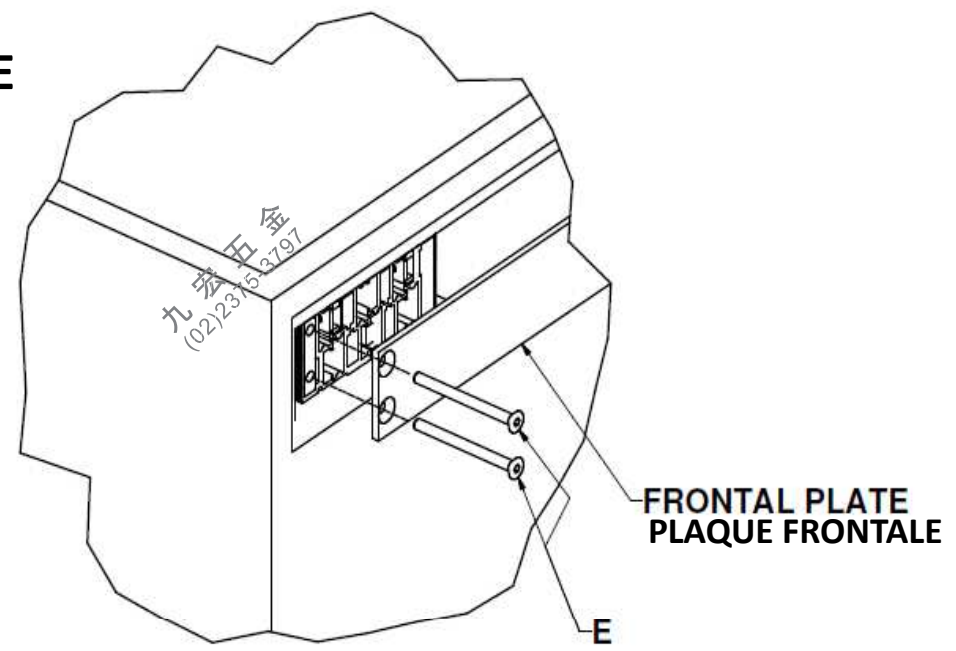

TABLE TOP ASSEMBLY ON THE CABINET
ASSEMBLAGE DU PANNEAU DE TABLE SUR LE CAISSON



FRONTAL PLATE MOUNTING MONTAGE DE LA PLAQUE FRONTALE



HOW TO DISMOUNT THE EXTERNAL SLIDE COMMENT DÉMONTER LA COULISSE EXTERNE

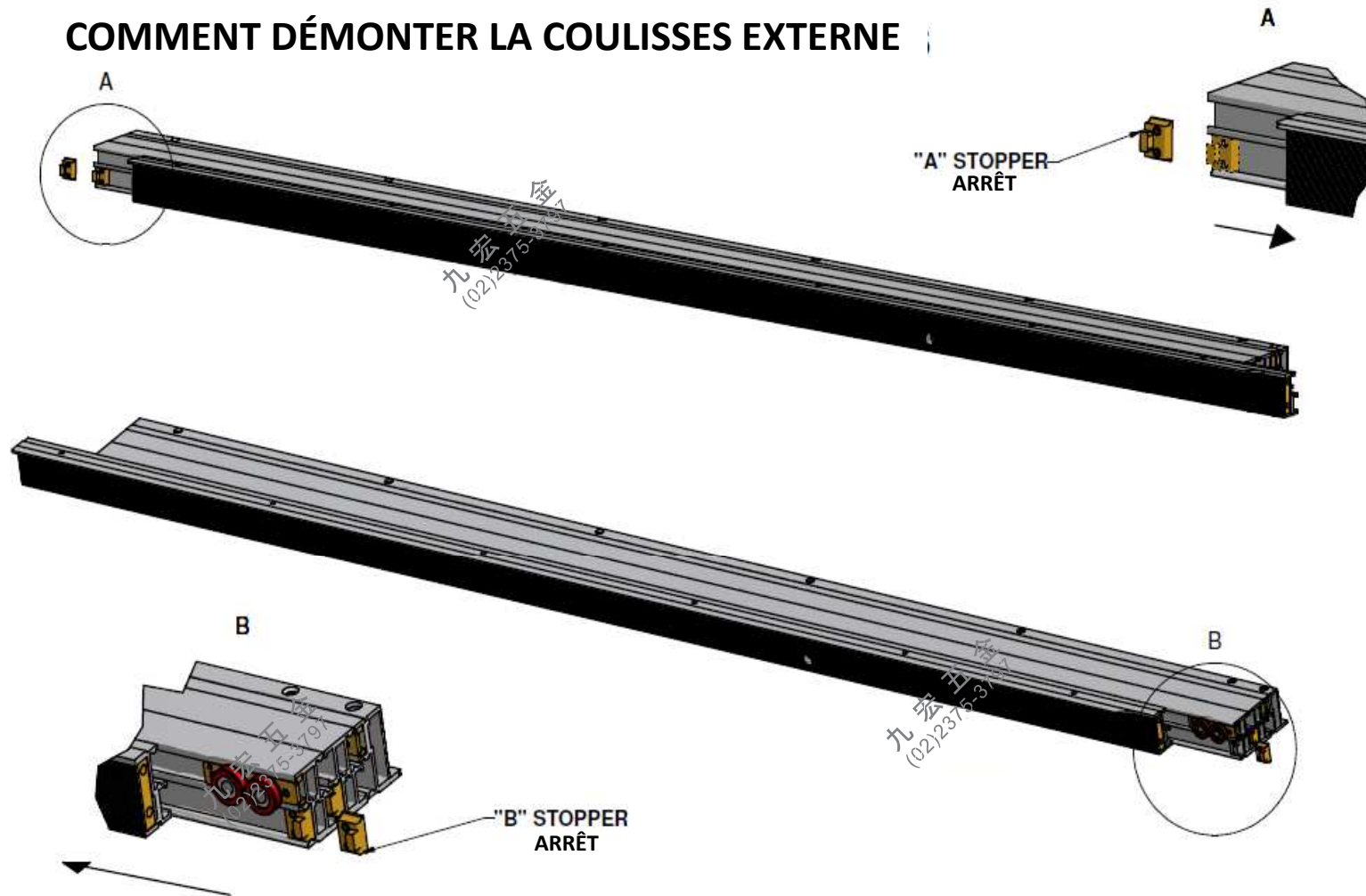

TO DISMOUNT THE EXTERNAL SLIDE :

- A) PUSH IT TO THE RIGHT THEN USING # 2.5 ALLEN KEY UNSCREW AND DISMOUNT STOPPER « A »
- B) PUSH IT TO THE LEFT AND DISMOUNT STOPPER « B »

IT IS NOW POSSIBLE TO PUSH THE SLIDE TO THE RIGHT AND DISSASSEMBLE IT FROM THE MECHANISM. TO REASSEMBLE, INVERT THE SEQUENCE OF THESE OPERATIONS

COMMENT DÉMONTER LA COULISSE EXTERNE :

- A) PUSSEZ LA VERS LA DROITE, UTILISEZ LA CLÉ ALLEN # 2.5, DÉVISSEZ ET DÉMONTÉZ L'ARRÊT « A »
- B) PUSSEZ LA VERS LA GAUCHE ET DÉMONTÉZ L'ARRÊT « B »

IL EST MAINTENANT POSSIBLE DE POUSSER LA COULISSE VERS LA DROITE ET DÉASSEMBLER DU MÉCANISME. POUR RÉASSEMBLER, INVERSEZ LA SÉQUENCE DES OPÉRATIONS.

L -
#2.5 ALLEN KEY
CLÉ ALLEN