

SLIDER M50 FLEX

安裝資料及數據

適用門寬：800~1600mm

適用門厚：40mm max.(含把手)

適用門重:50kg

適用型式:外掛式櫥櫃拉門

代號 (施工圖代號)	表示部位	尺寸(mm)
LI	櫃體內徑寬度	
HI	櫃體內徑高度	
HA	門片高度	
LA	單片門片寬度	
SPI	櫃體內中間隔板厚度	
SPE	櫃體側板厚度	
SPC	櫃體上頂板厚度	
SPB	櫃體下底板厚度	
SPE	門片覆蓋側板距離(厚度)	
AA	門片與中隔板之間距離	

產品五金內容清單

※配件皆有代號，安裝時請對照說明書上相對應的代號(零件)

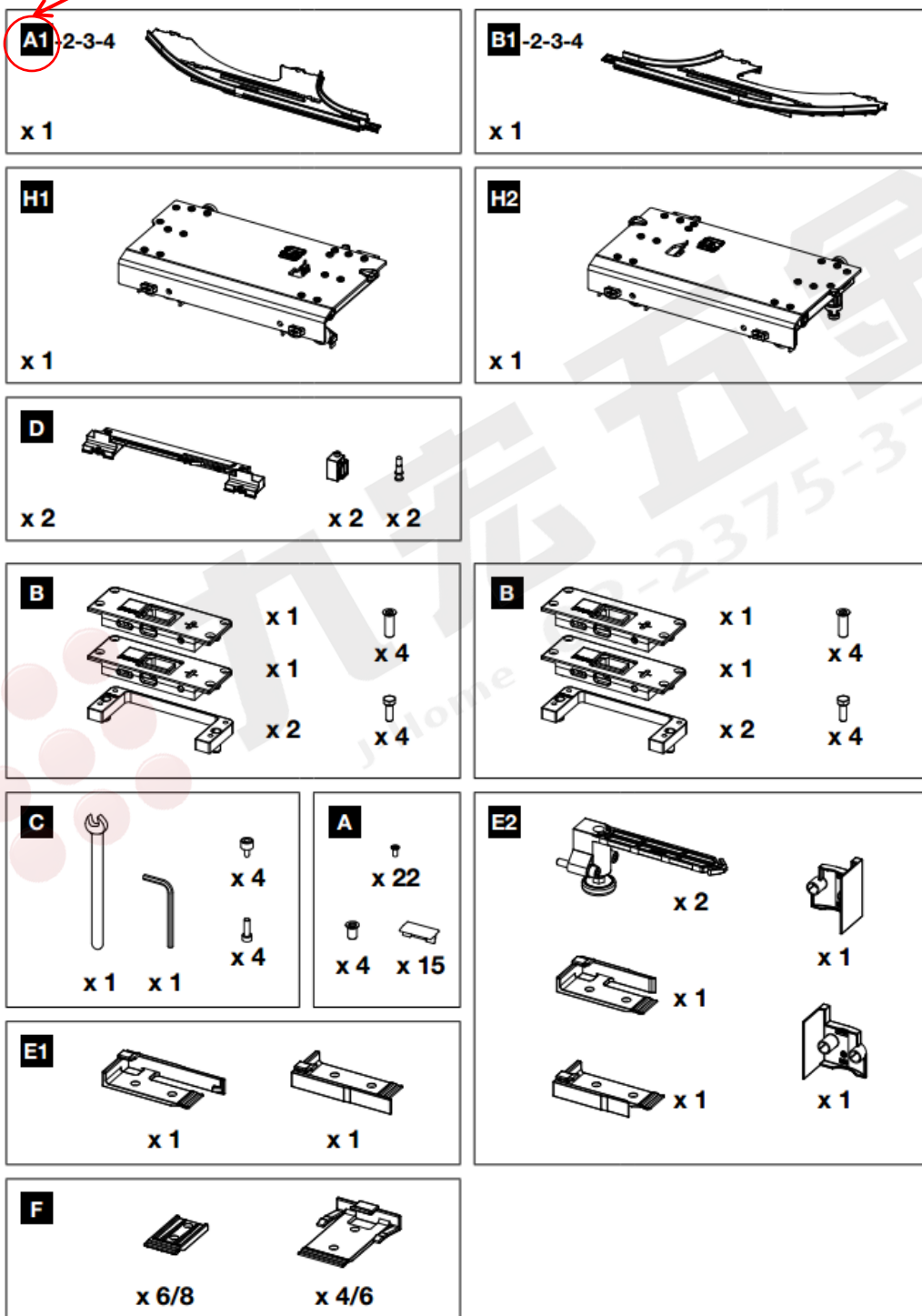

產品五金內容清單

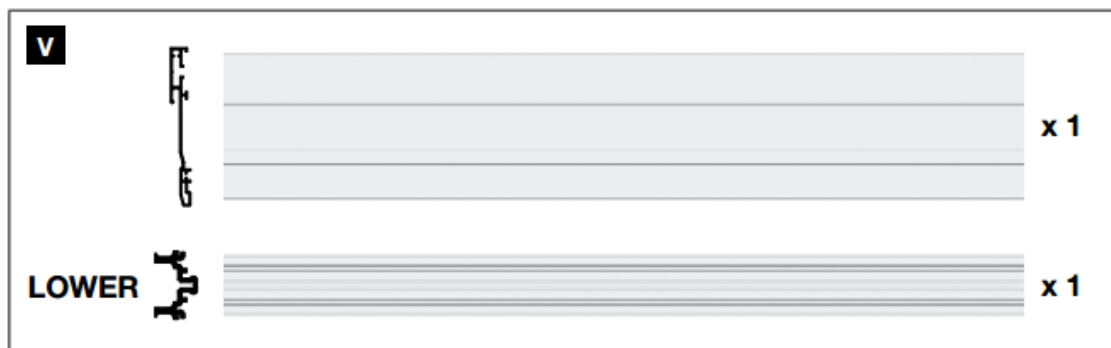
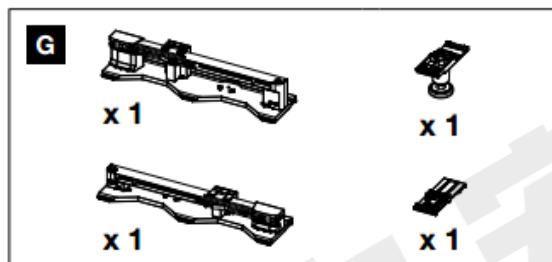
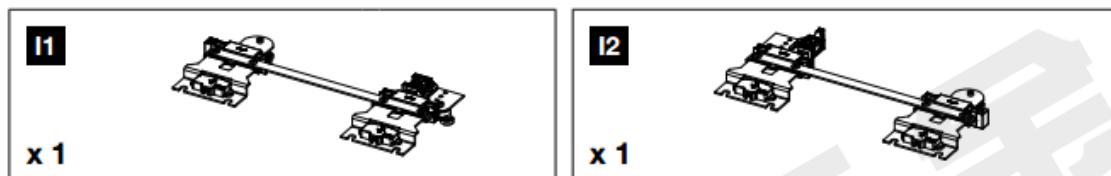
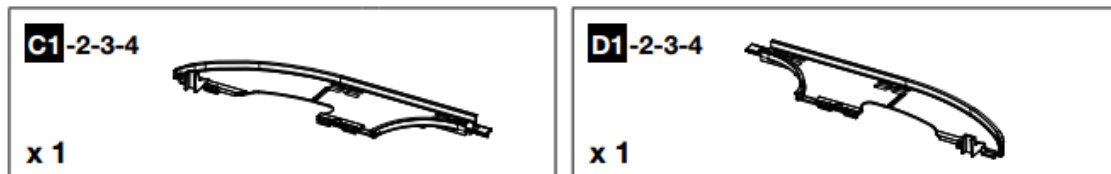

安裝部位簡要圖解

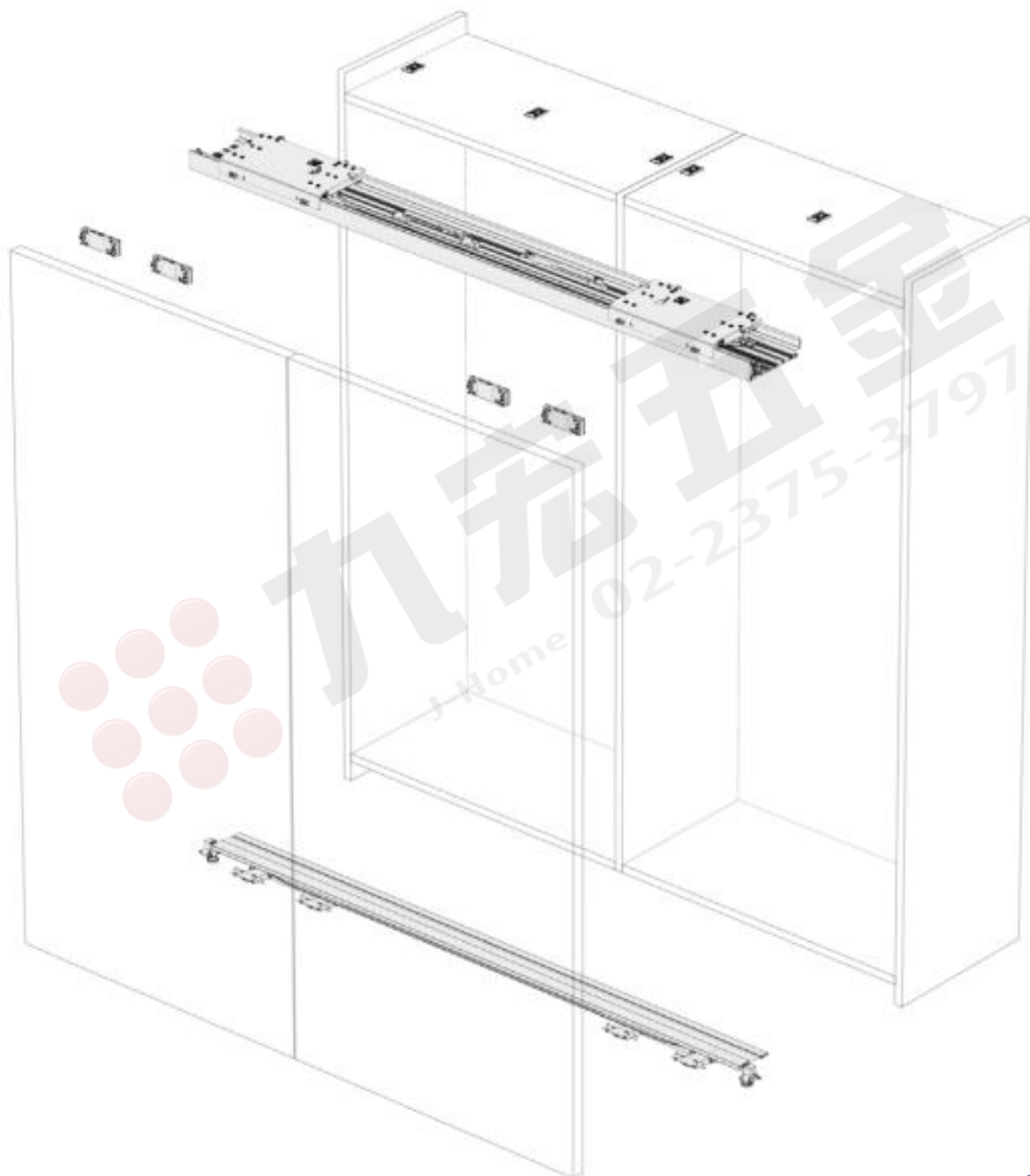

安裝概要圖

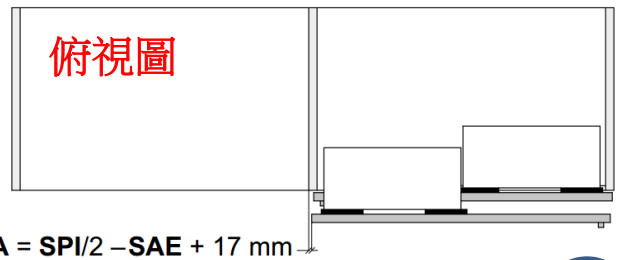
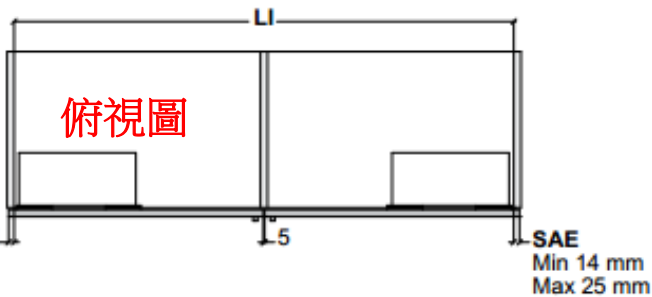
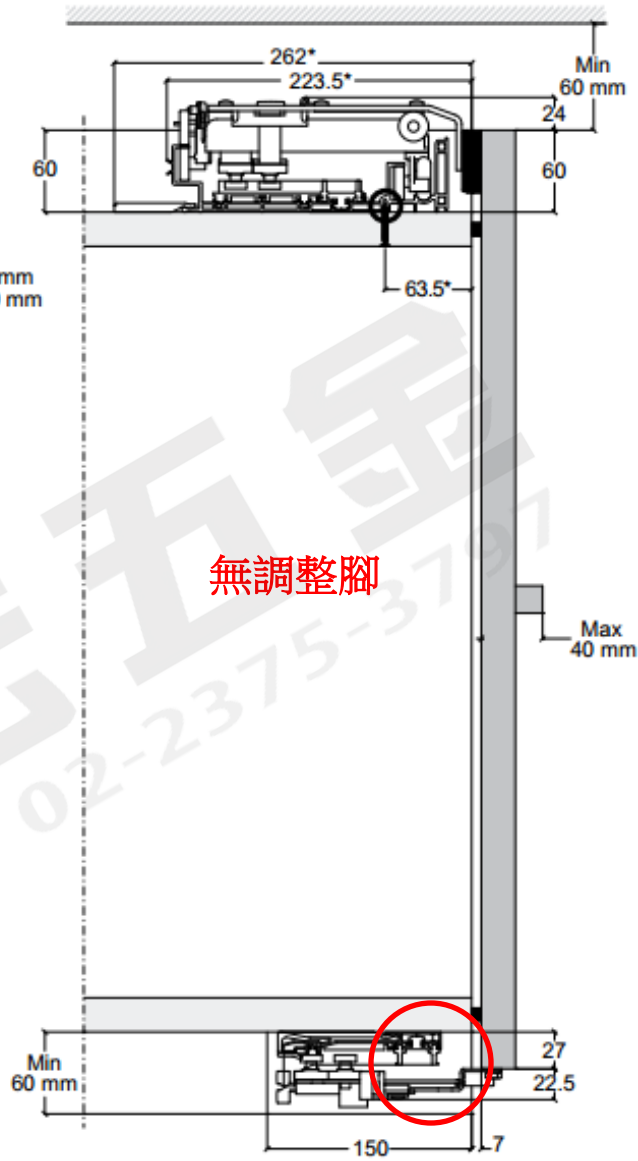
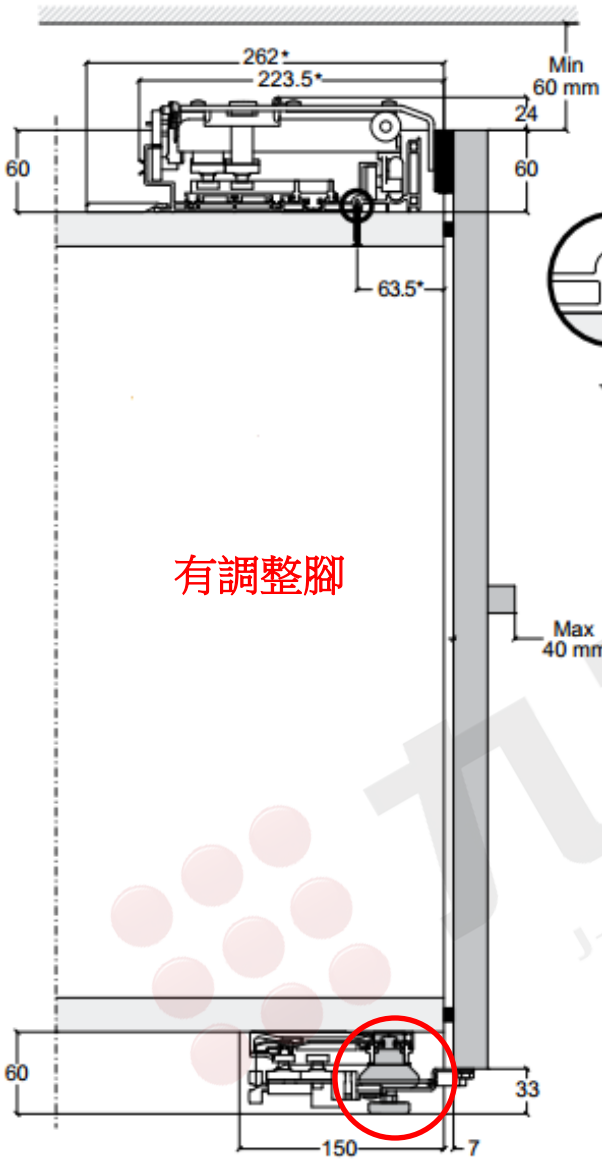

參照頁次

1

5

櫃體前置作業

(櫃體內徑 1531-2330 mm)

各部位視點

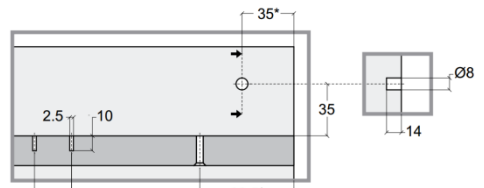
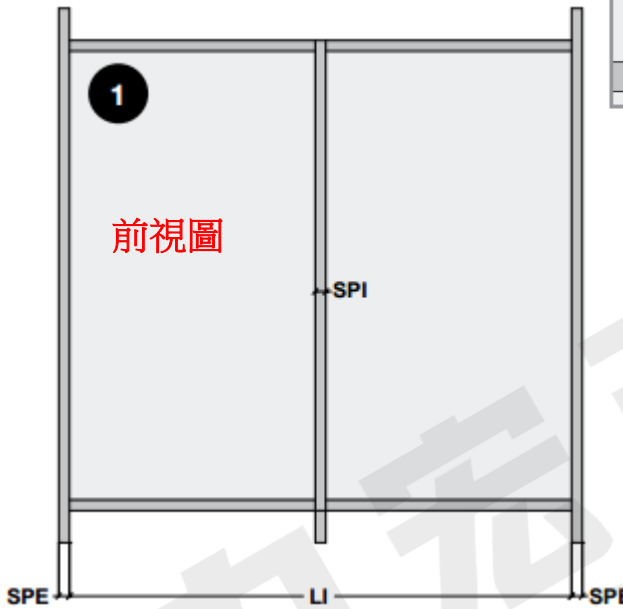
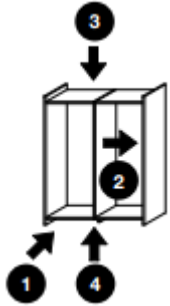

對應頁次



沒裝支撐腳
不需此步驟

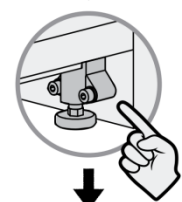

對應頁次

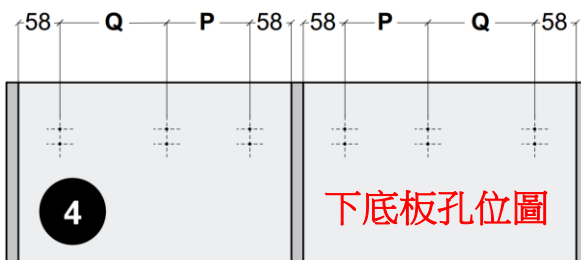
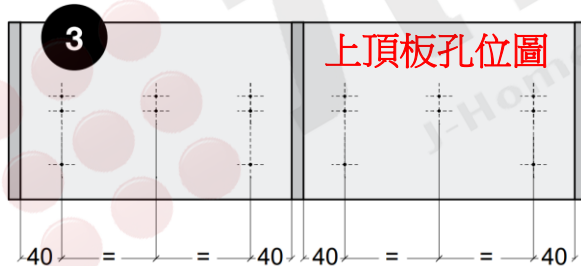
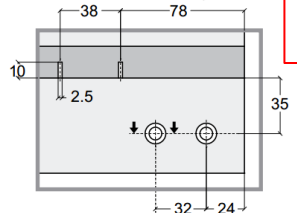

P	$LI/4 - SPI/2 - 70 \text{ mm}$
Q	$LI/4 - 46 \text{ mm}$

參照頁次 1

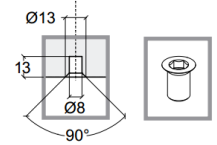

櫃體前置作業

(櫃體內徑 2330 - 3200 mm)

各部位視點

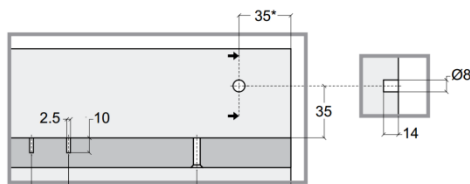
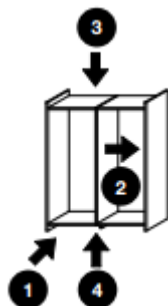

對應頁次

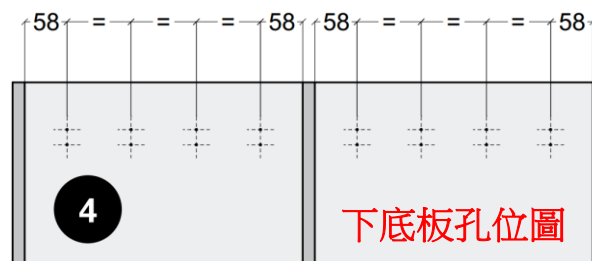
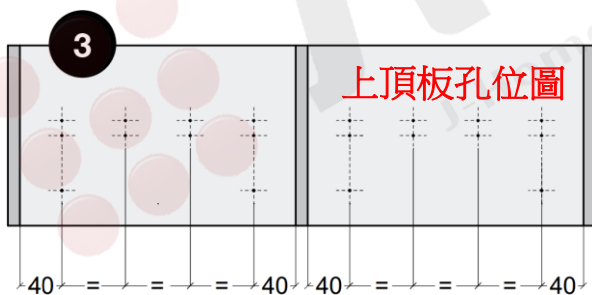

沒裝支撐腳
不需此步驟

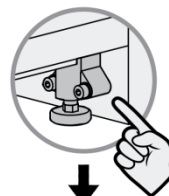

對應頁次

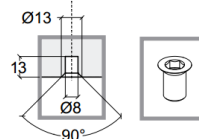
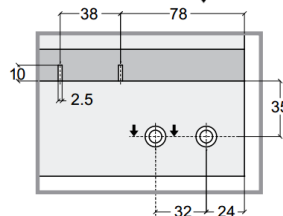

門片前置作業

(左片門板施工孔位圖)

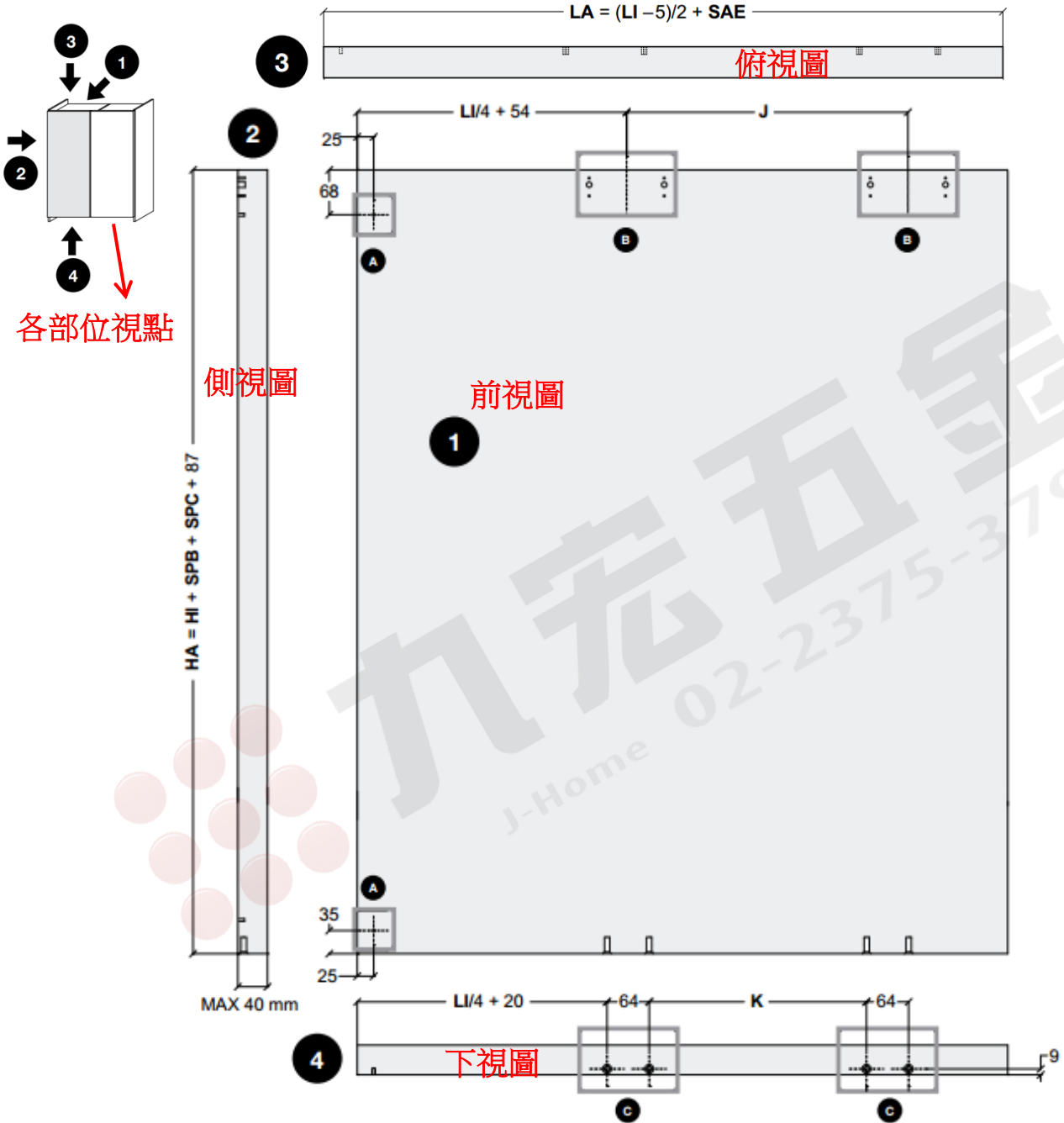

LI (mm)	J (mm)	K (mm)
1531-1930	254	177
1931-2330	354	277
2331-2730	454	377
2731-3200	554	477

J、K數值對應 LI 數值

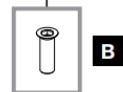
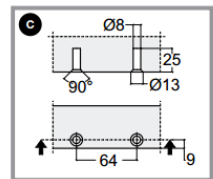
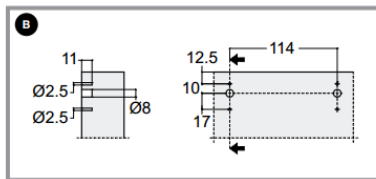
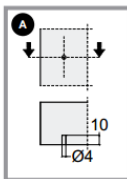

門片前置作業

(右片門板施工孔位圖)

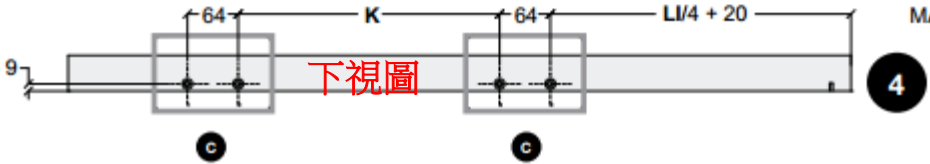
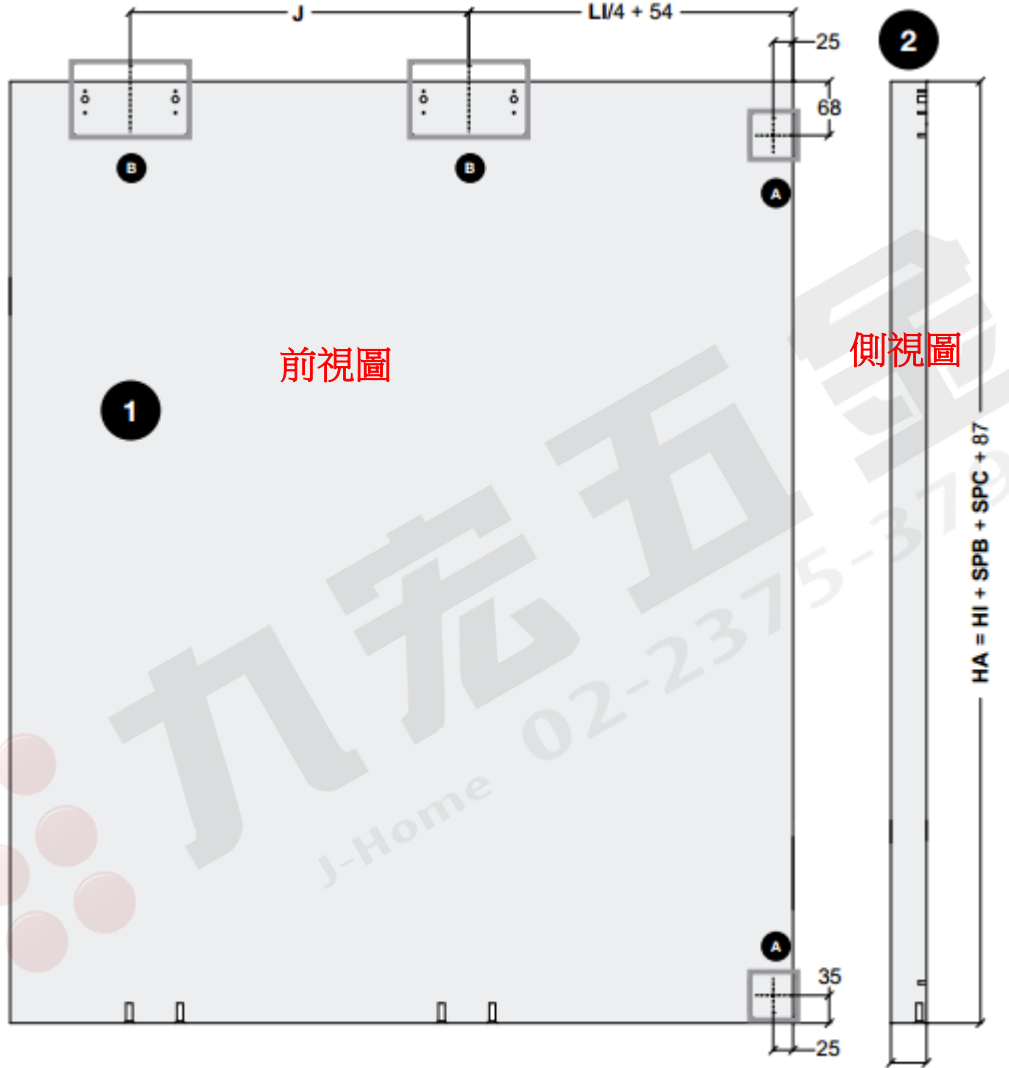
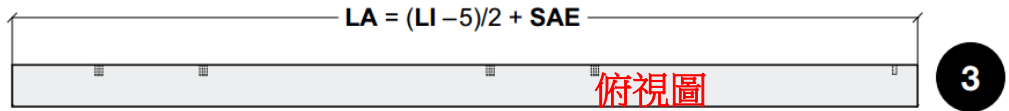
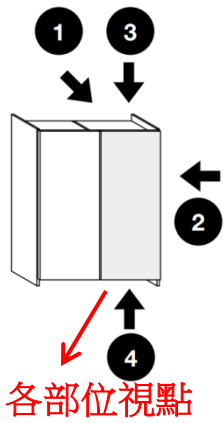

LI (mm)	J (mm)	K (mm)
1531-1930	254	177
1931-2330	354	277
2331-2730	454	377
2731-3200	554	477

J、K數值對應 LI 數值

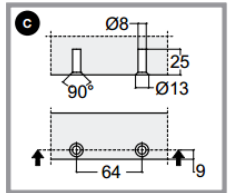
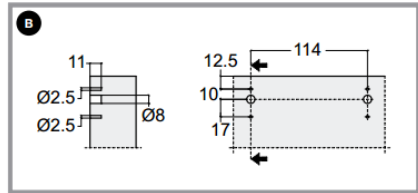
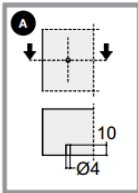

支撐腳安裝

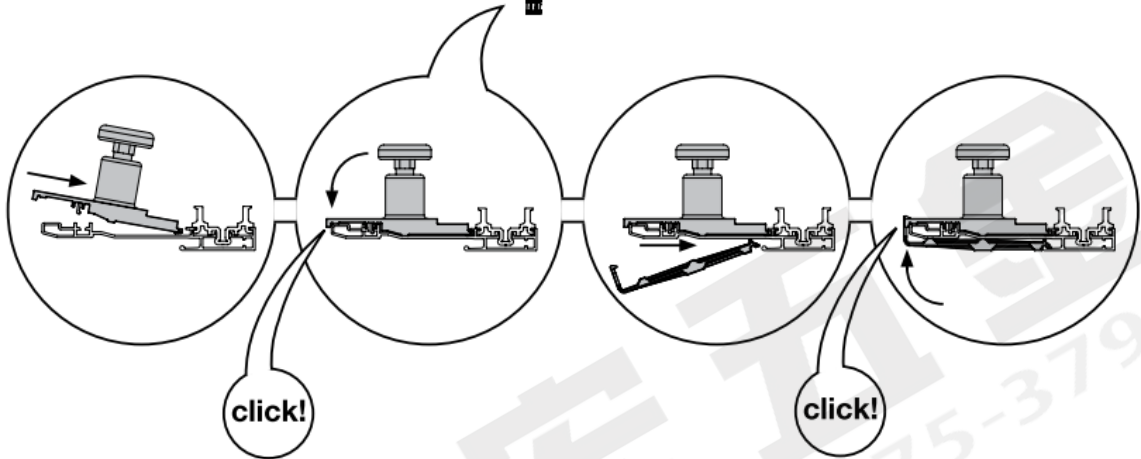
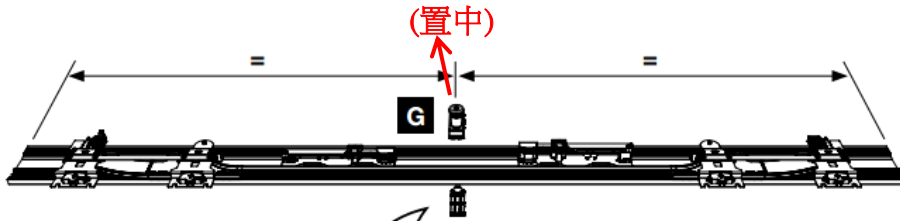

E2

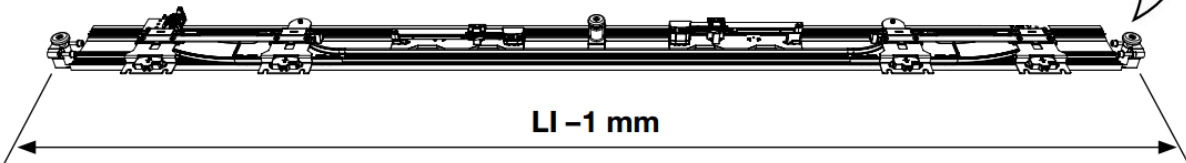
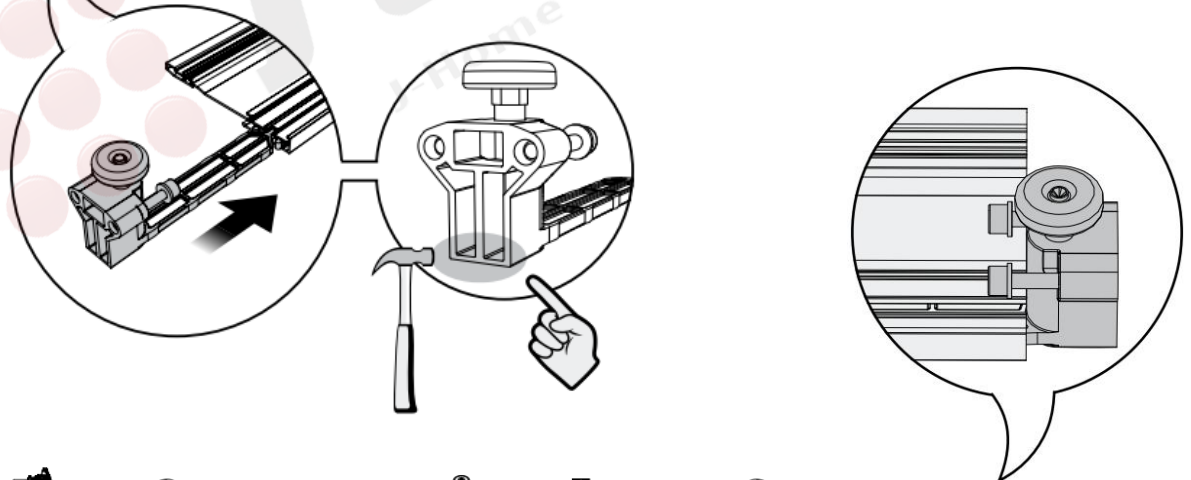

櫃體下軌安裝示意圖1

(無調整腳)

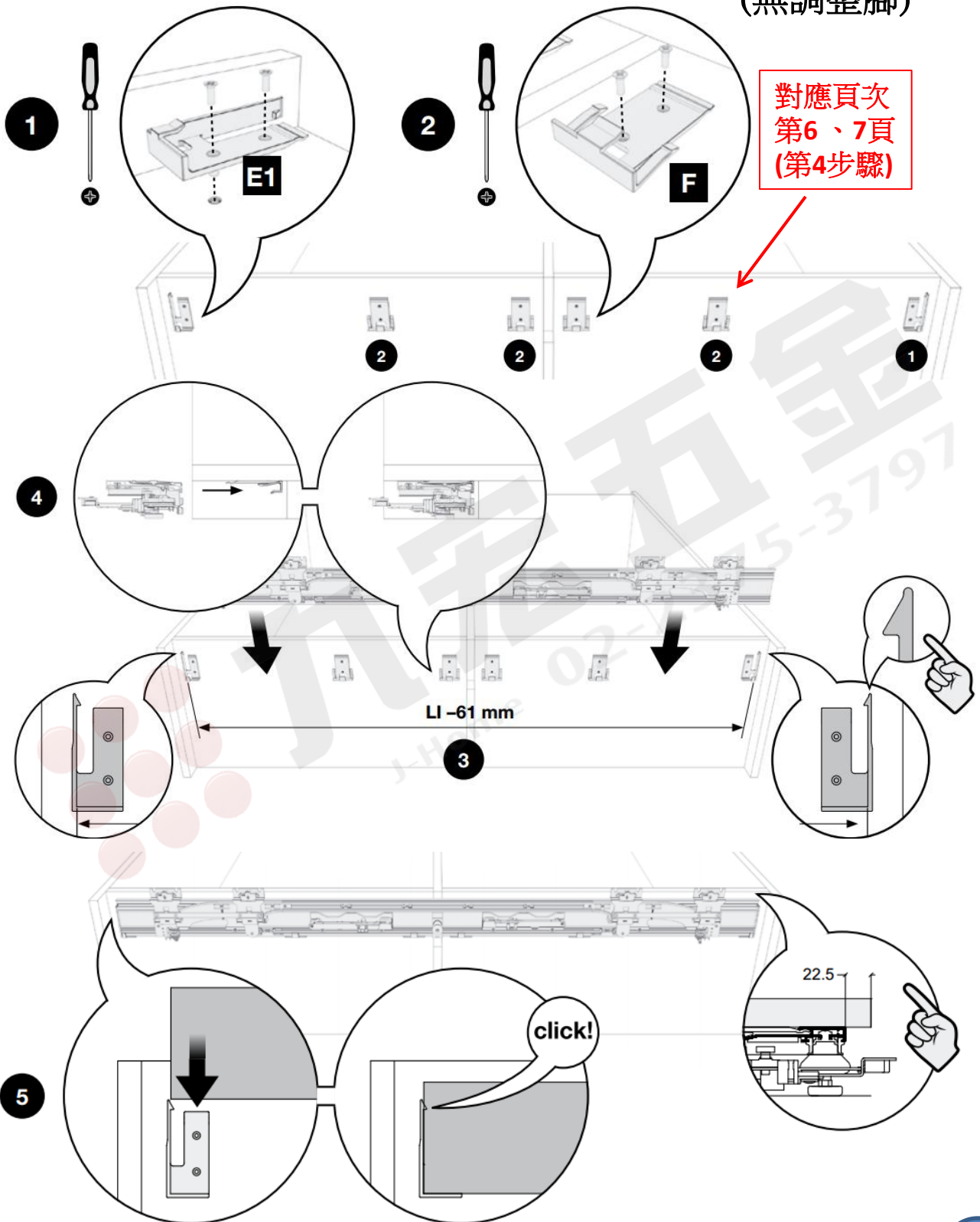

櫃體下軌安裝示意圖2

(有調整腳)

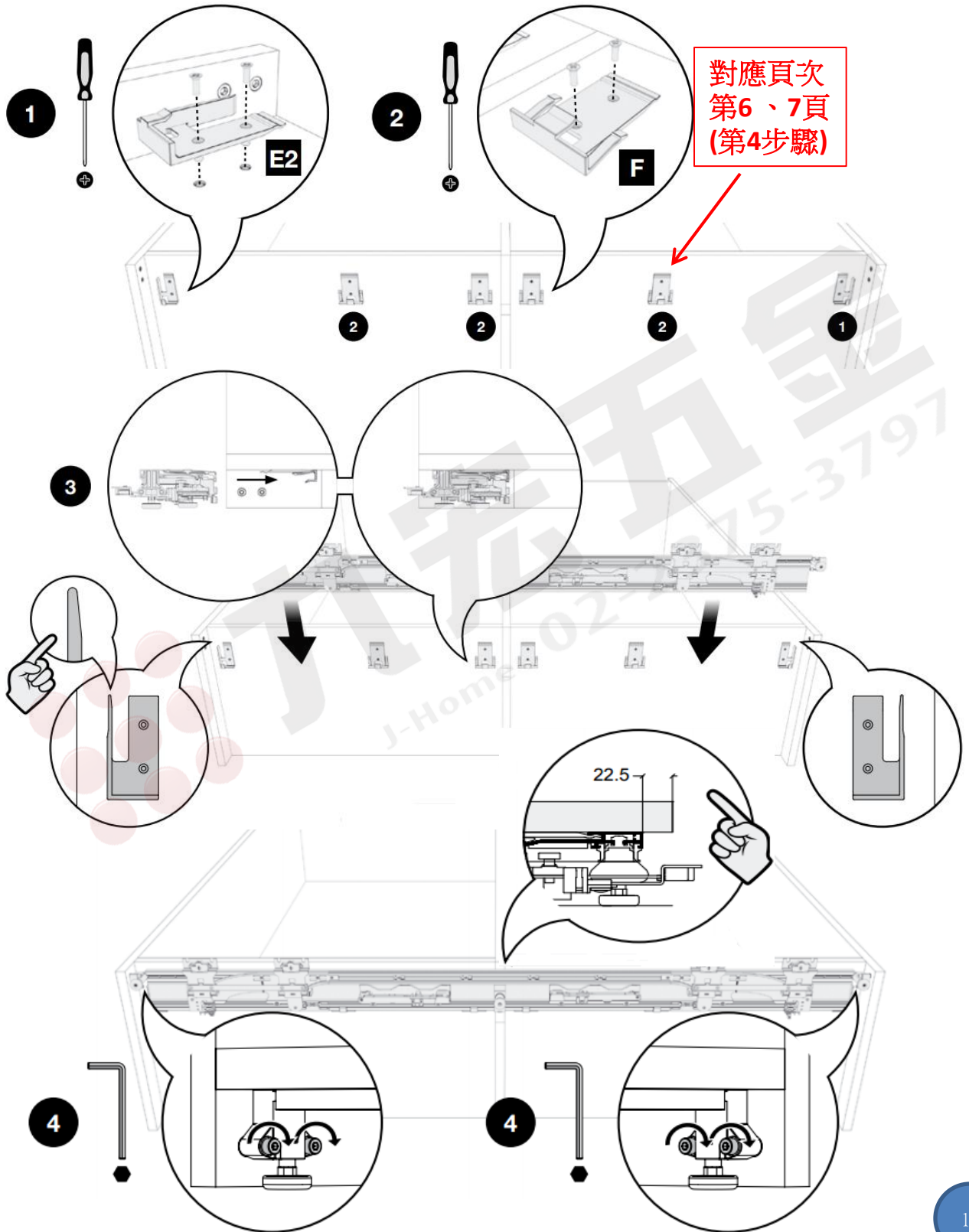

櫃體上軌安裝示意圖1

(利用軌道快裝件)

對應頁次
第6、7頁
(第3步驟)

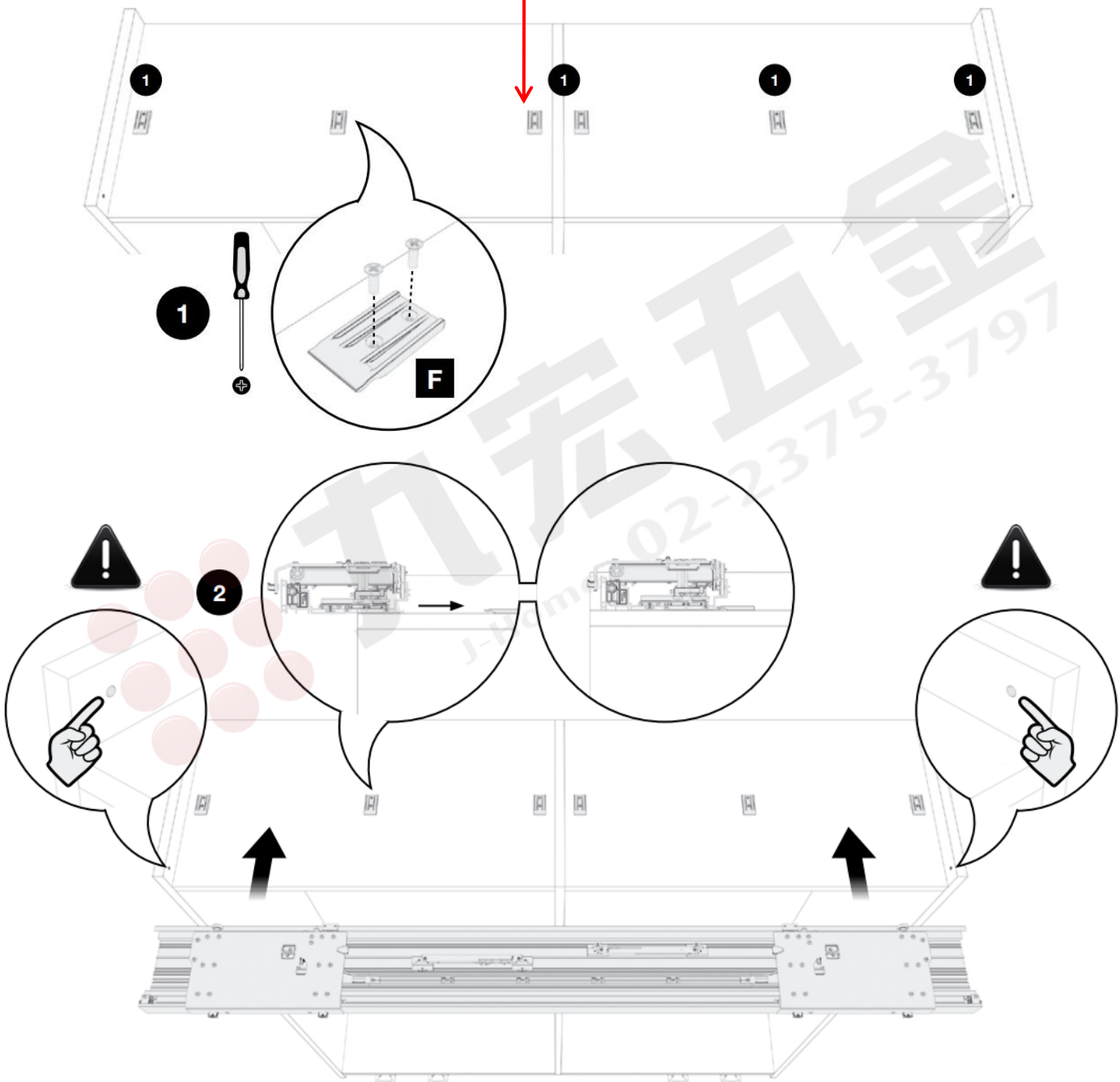

櫃體上軌安裝示意圖2

(上檔)

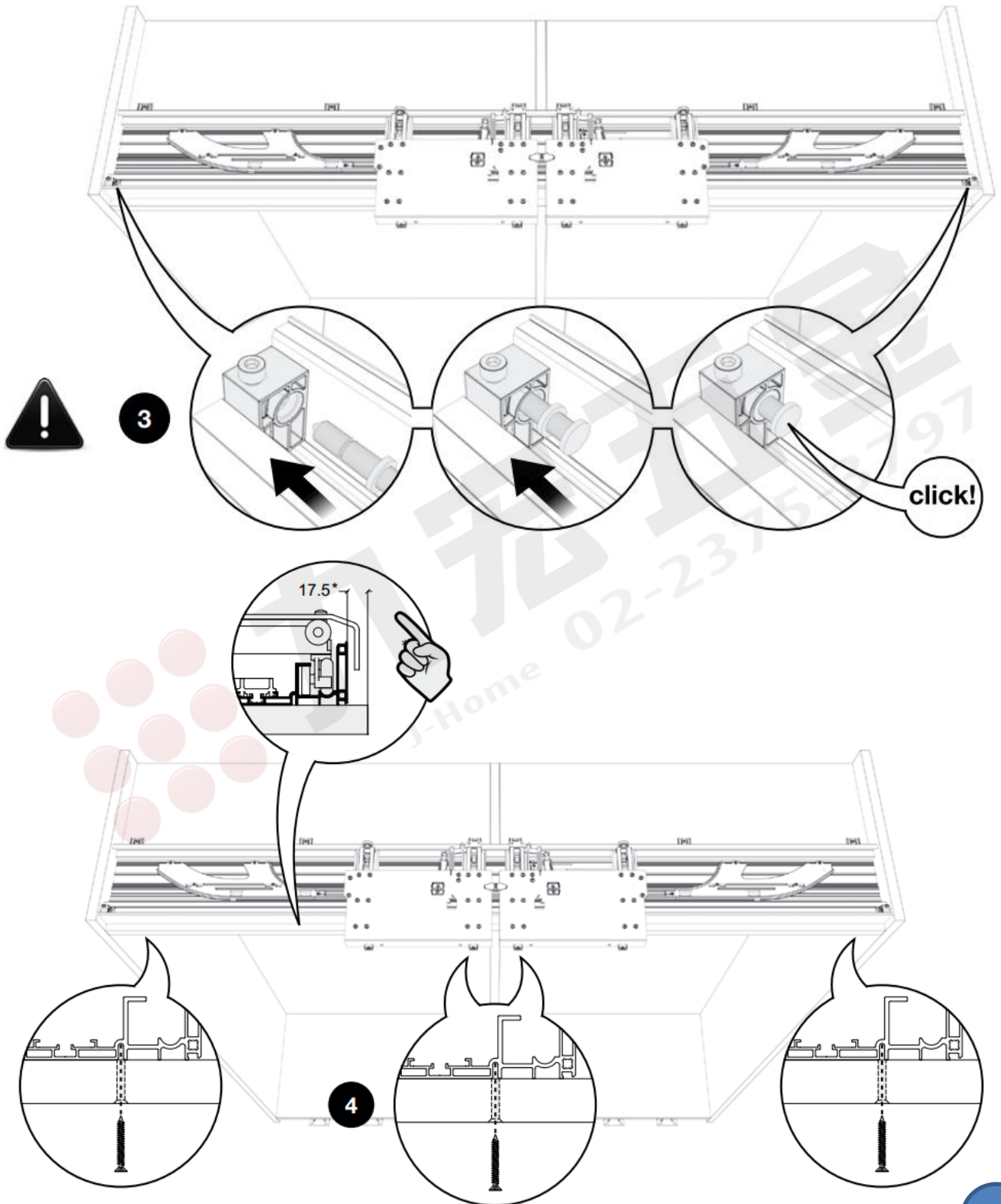

門片安裝前準備

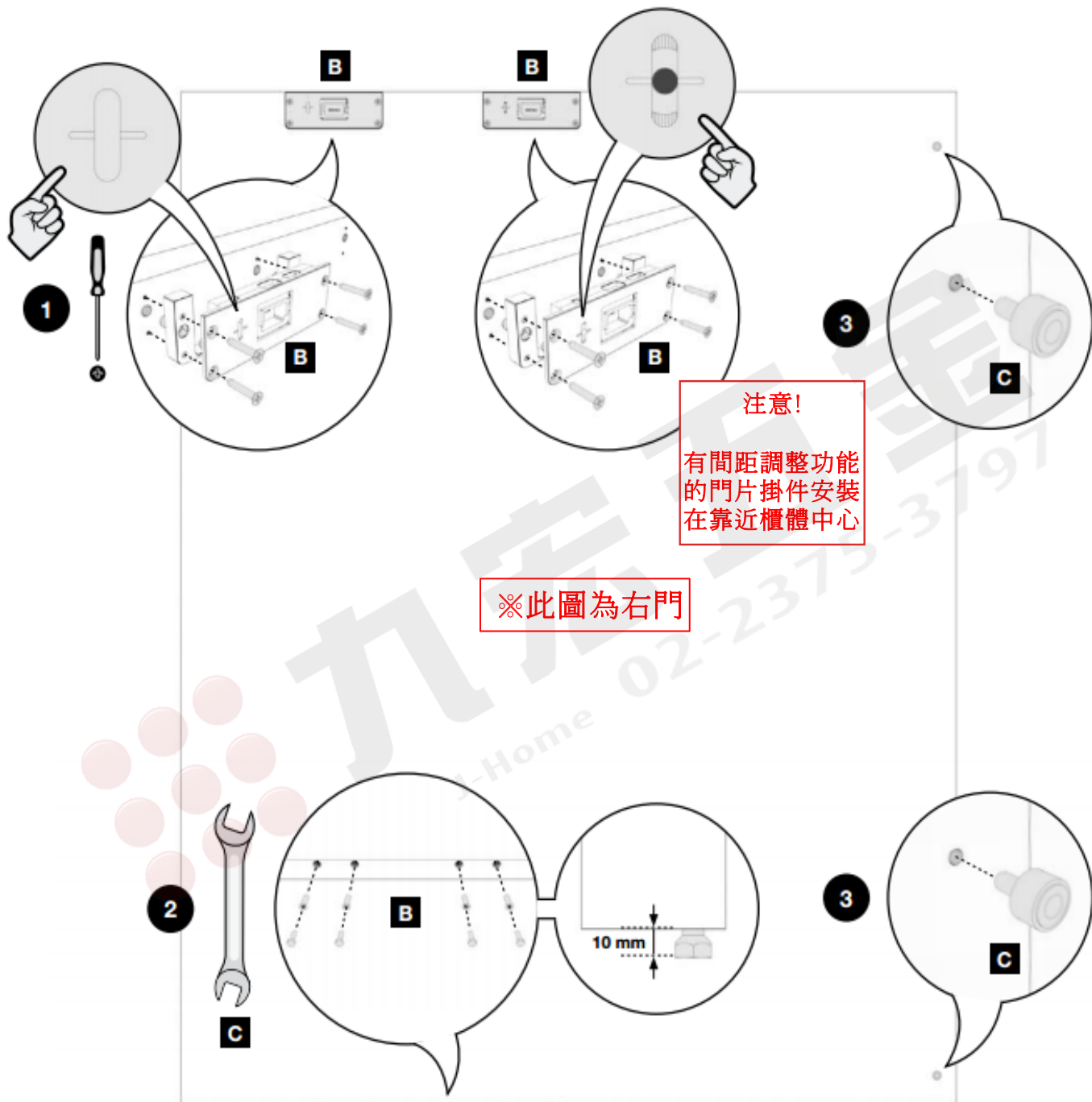

※左門部分請重複步驟 ①~③

門片安裝示意圖1

※注意!此產品不附水平器，請自備!

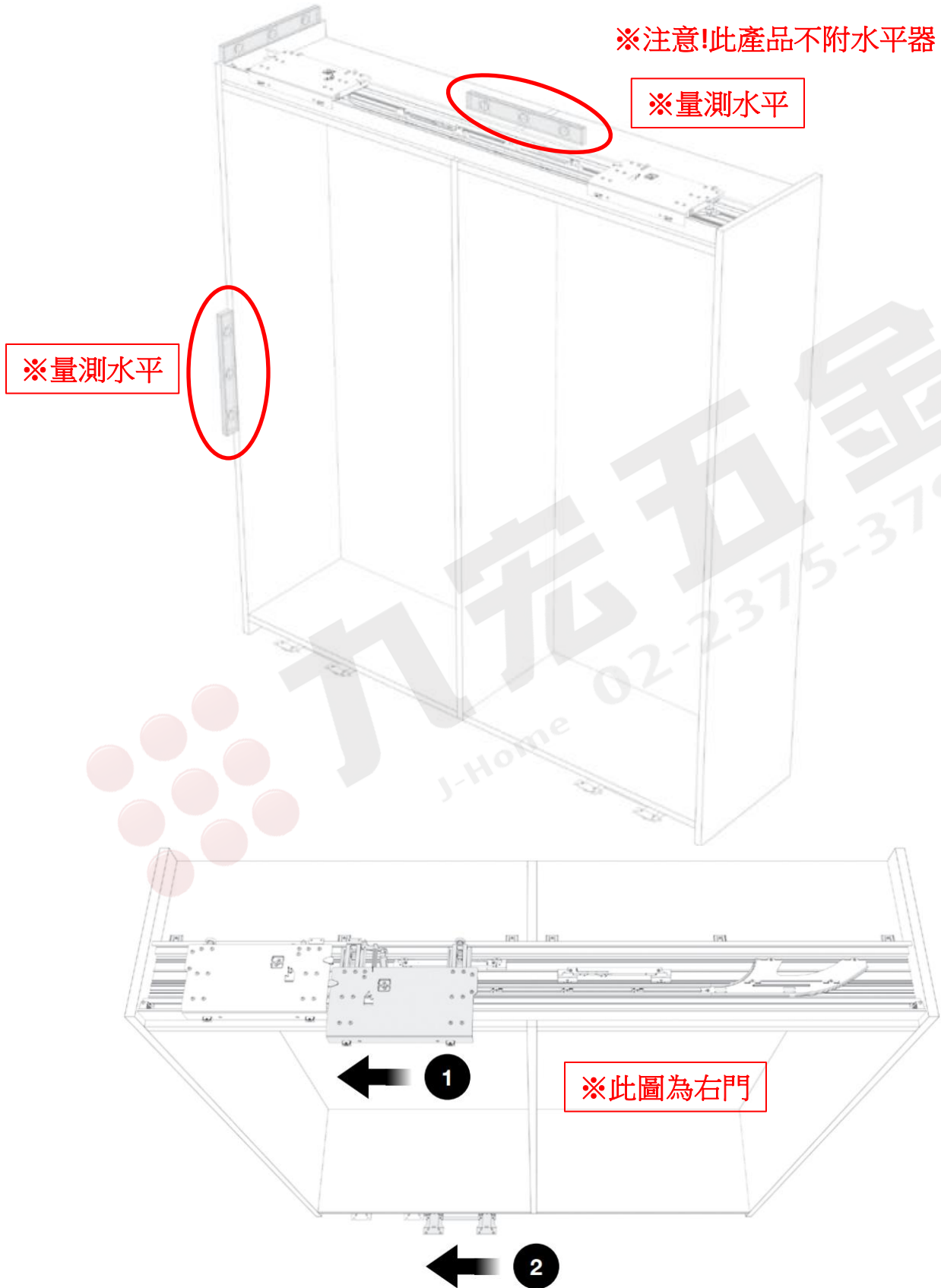

門片安裝示意圖2

3 →

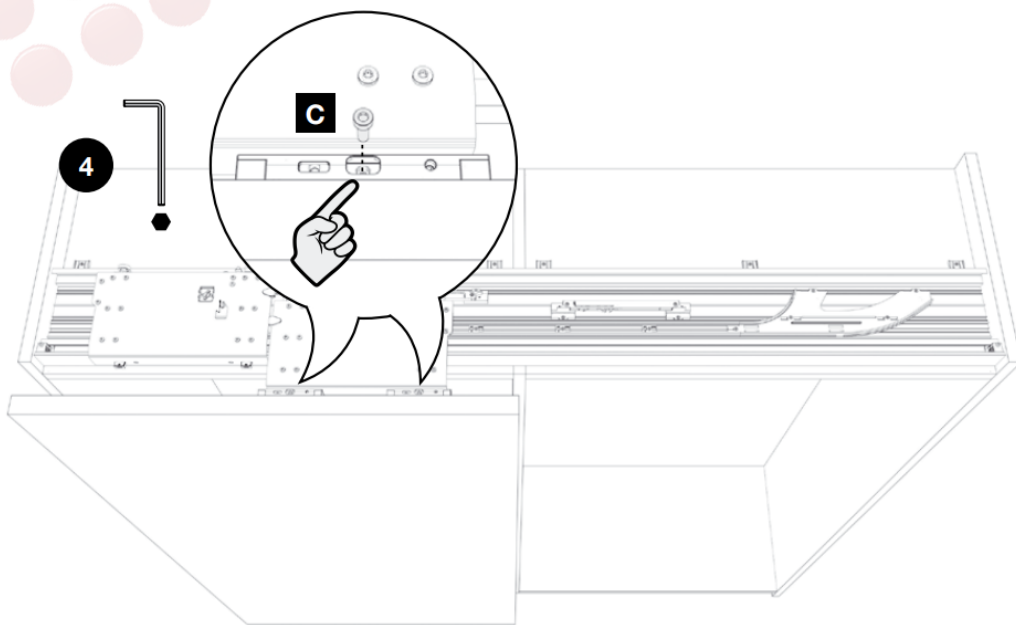
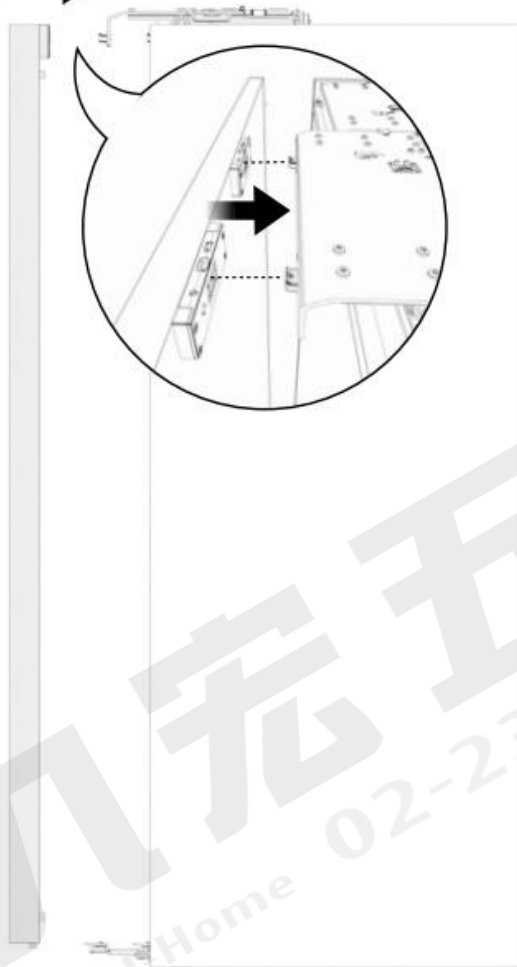

門片安裝示意圖3

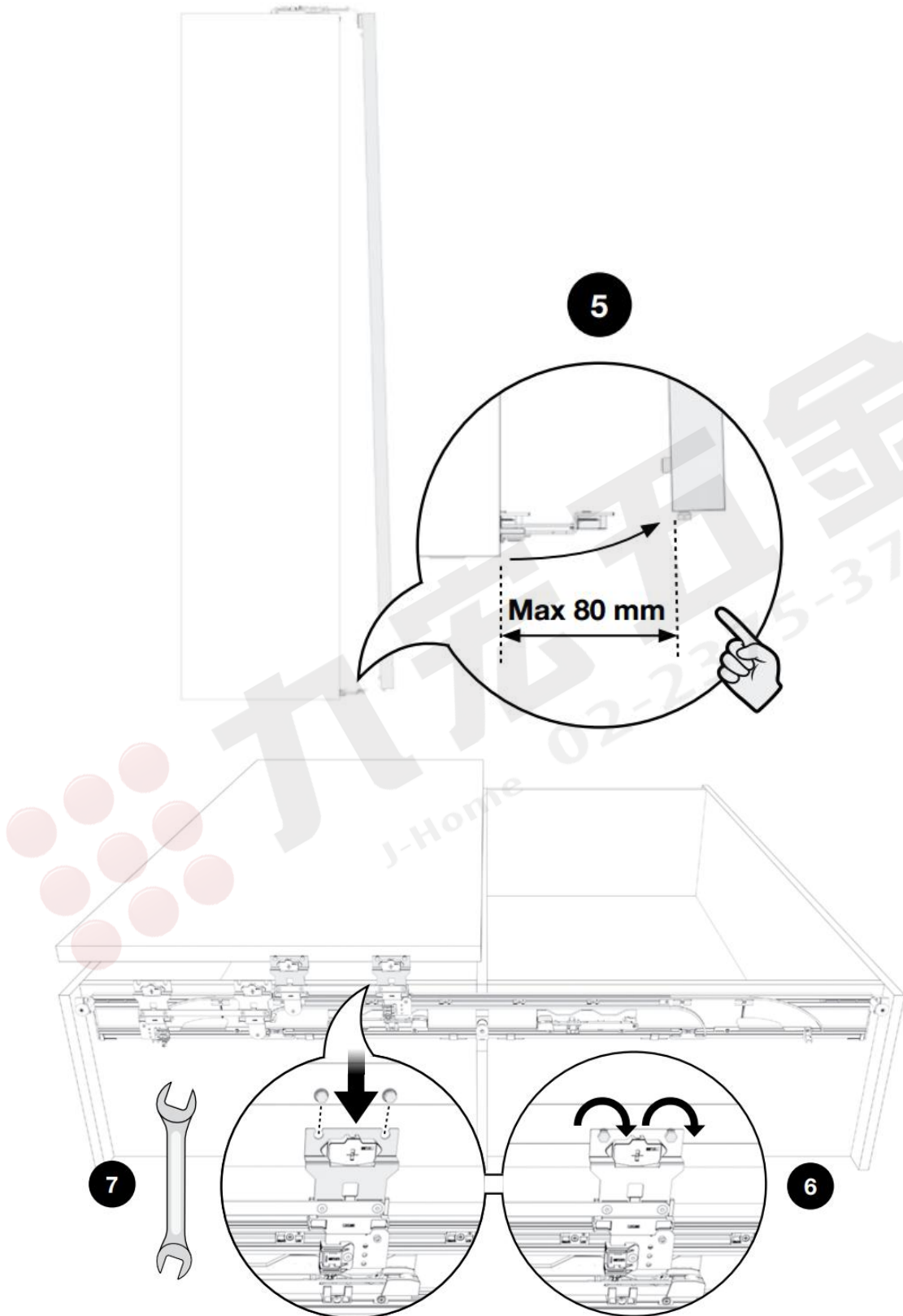

※左門部分請重覆步驟 ①~⑦

門片調整1 - 水平調整

※須將門片呈現開啟狀態

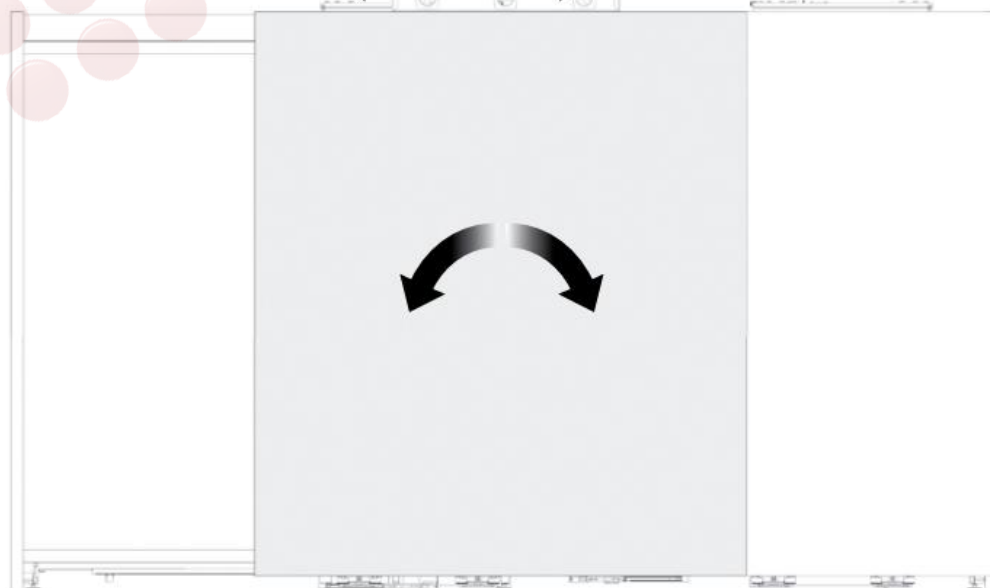
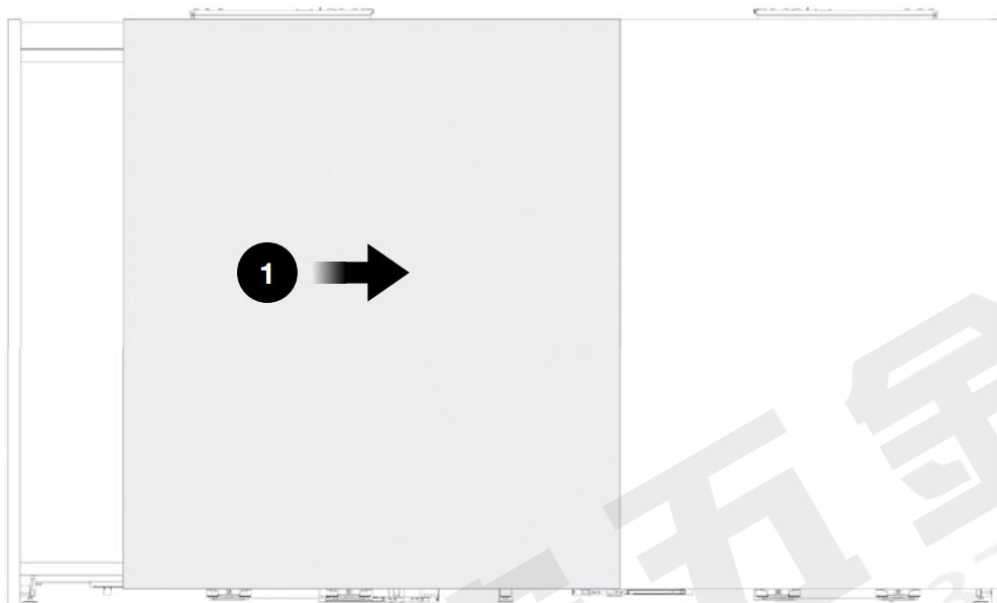

門片調整2 - 垂直調整

※須將門片呈現關閉狀態

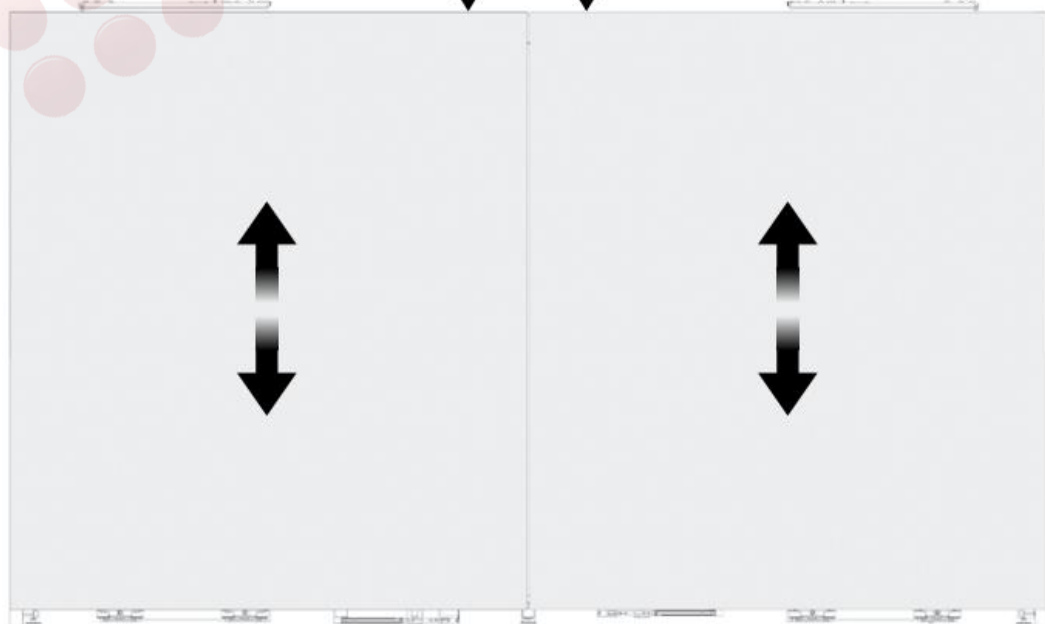
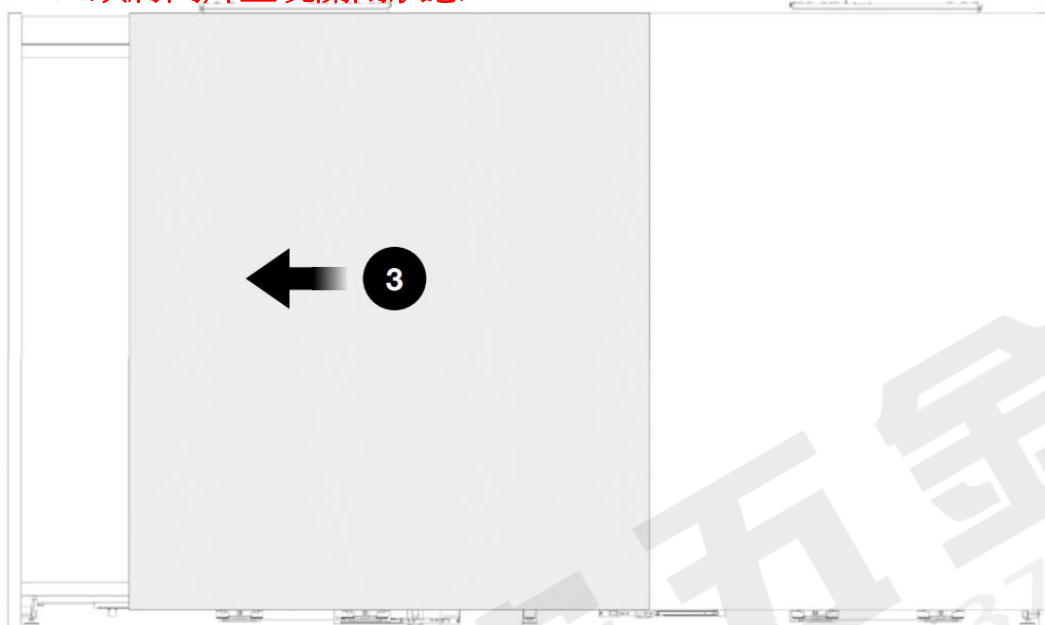

門片調整3 - 間距調整

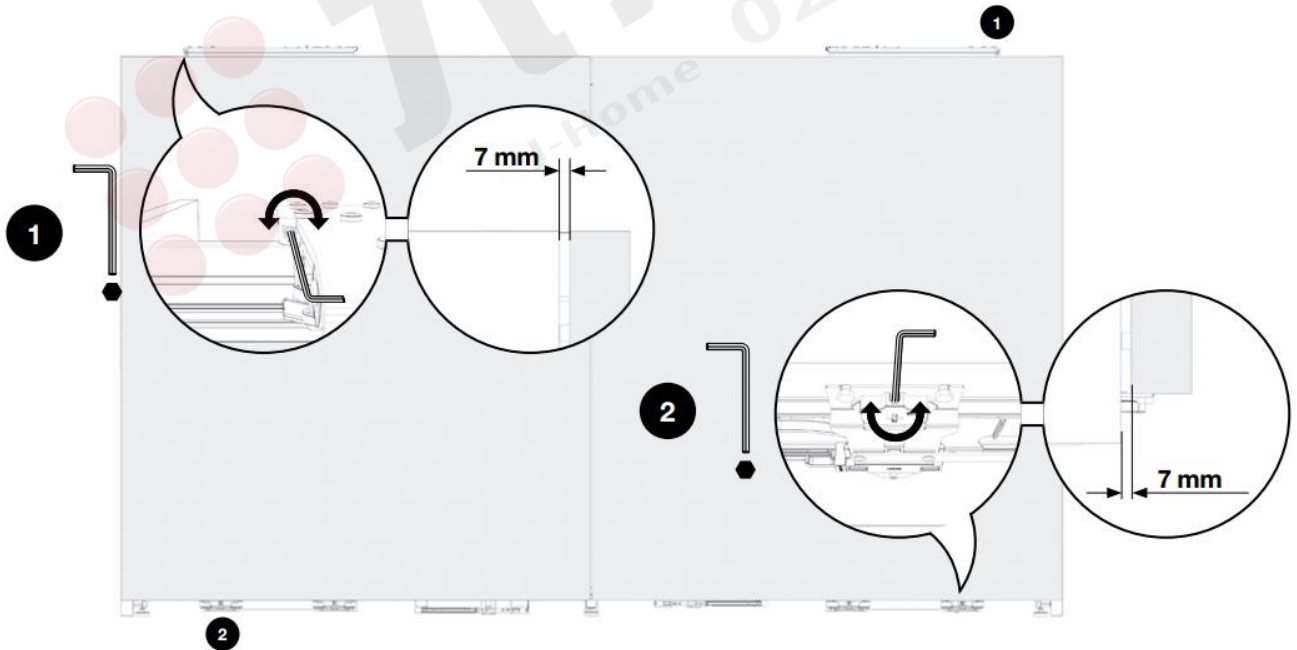
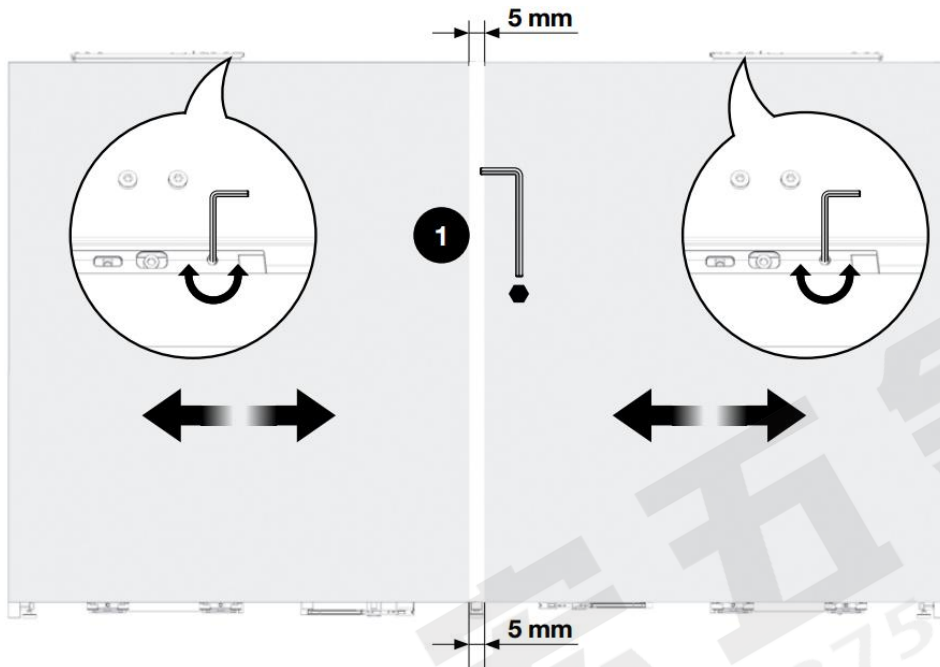

門片調整4 - 行進速度

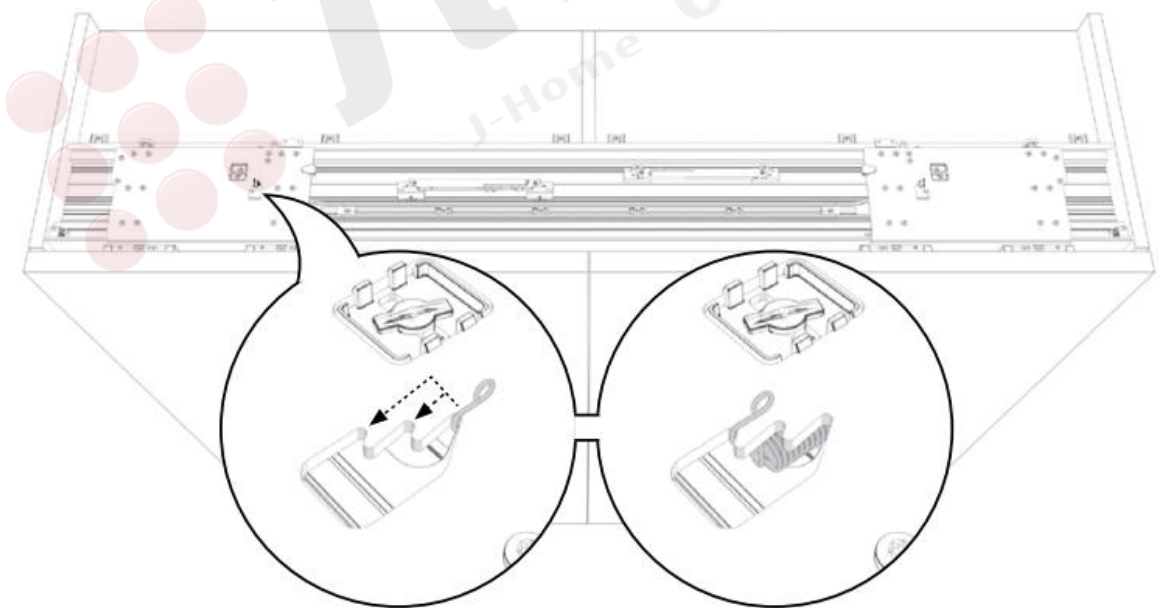
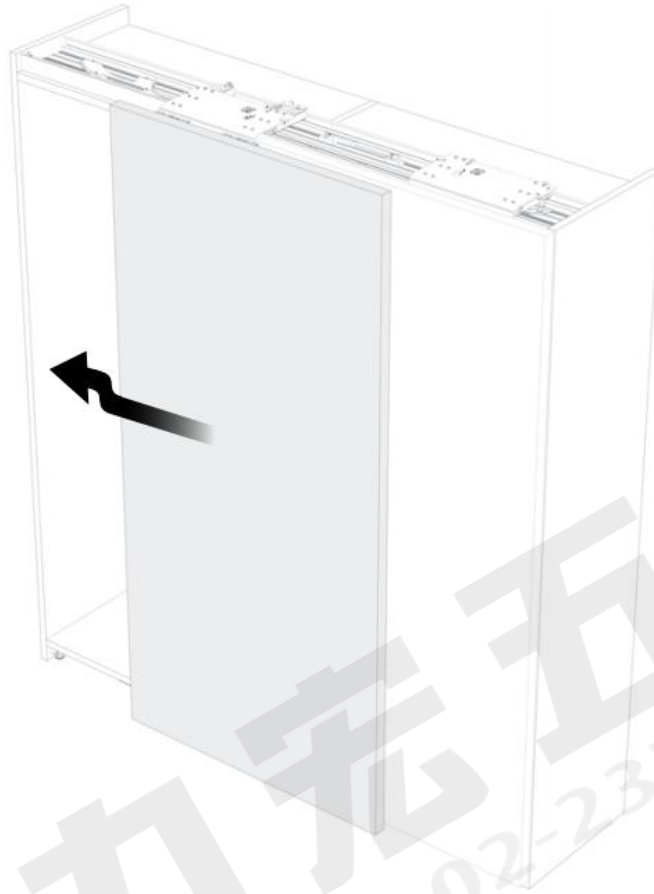

慢



快

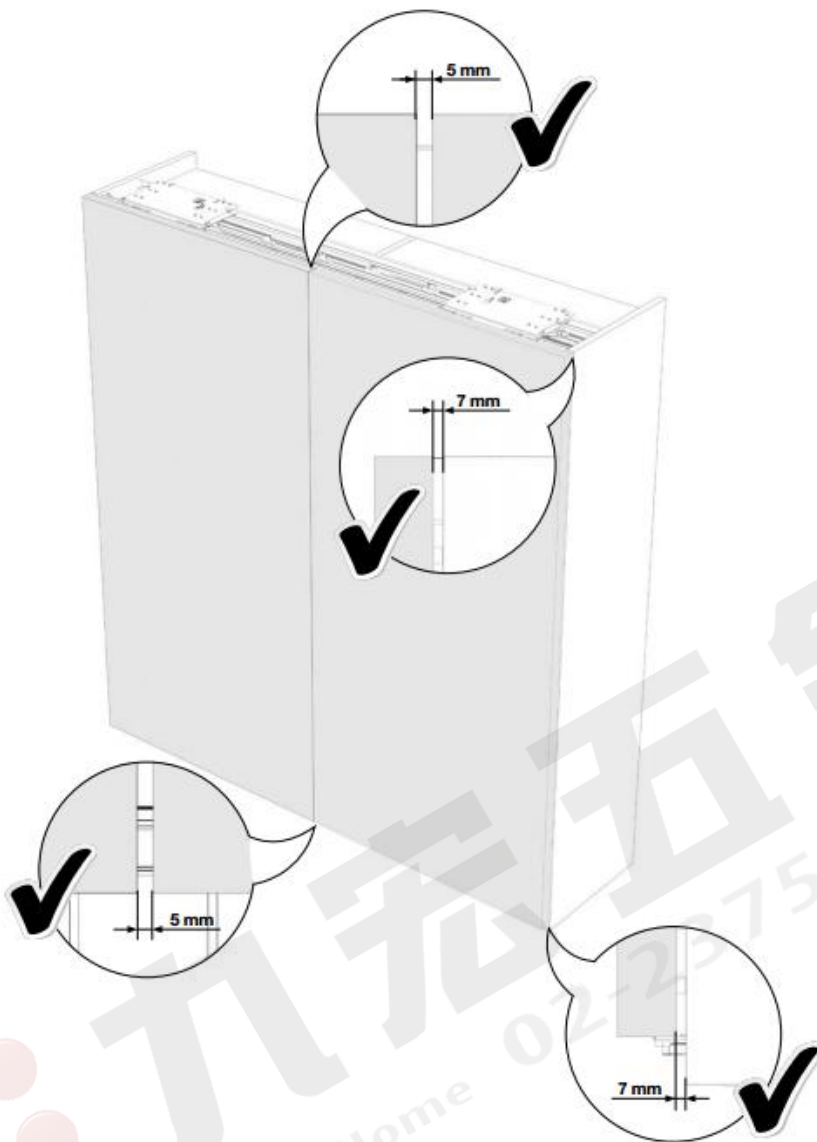

J-Home 02-2575-3797

