



Advanced Technology for Beds

Mod. Aladino Standard **New 18**

Ribalta verticale matrimoniale
Double hide-away bed system

Istruzioni di montaggio / Assembly instructions

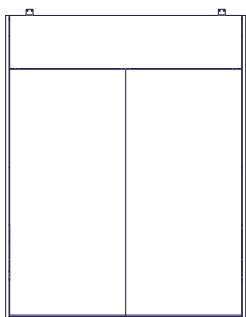
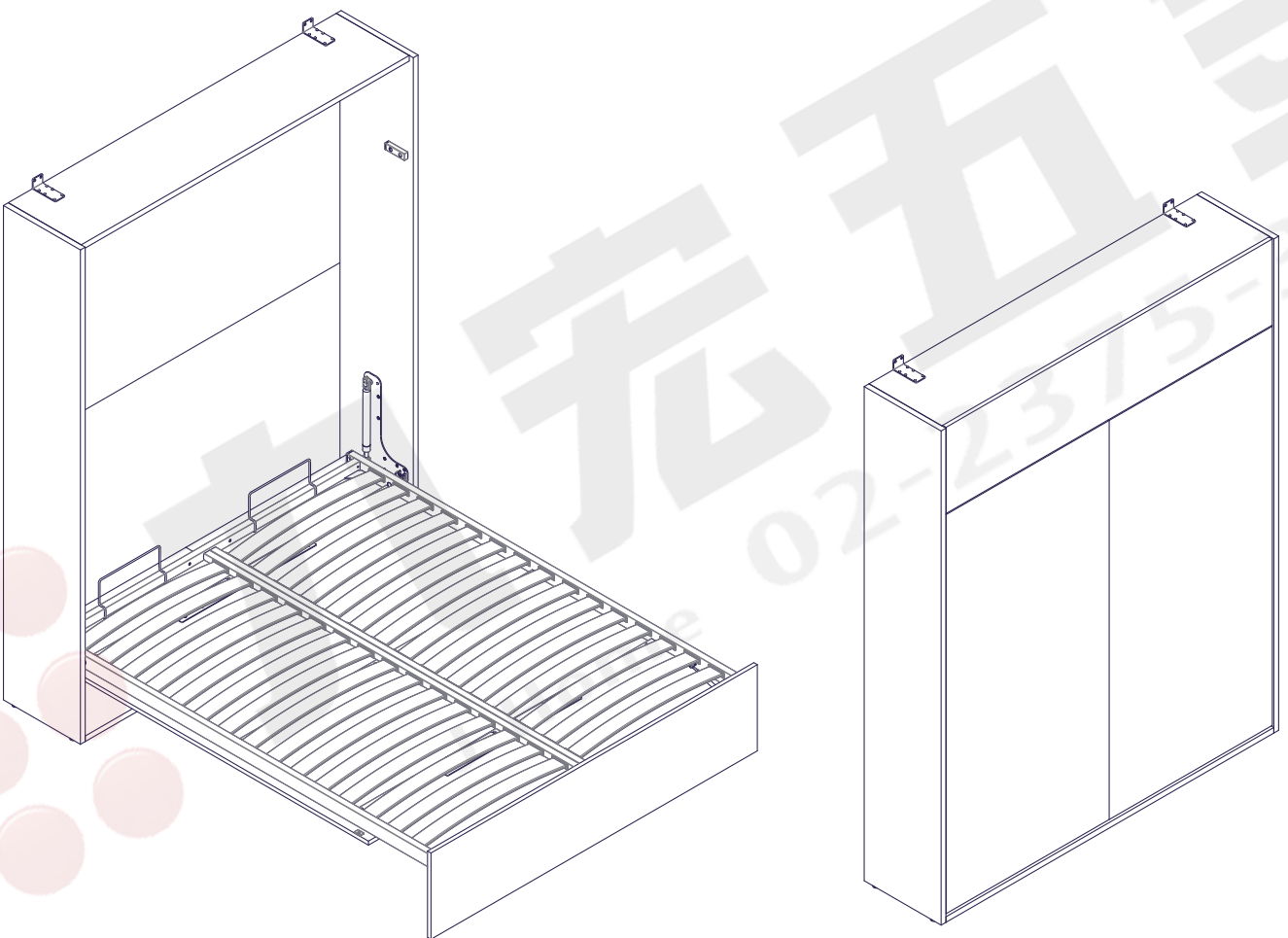

"ALADINO NEW 18" 1420 x 2000 mm

"ALADINO NEW 18" 1620 x 2000 mm

"ALADINO NEW 18" 1820 x 2000 mm

ITALIANO

ENGLISH

27/10/2018

M A D E I N I T A L Y

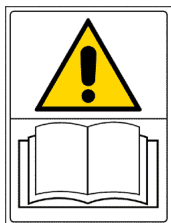

MANUALE D'USO E MANUTENZIONE "ISTRUZIONI ORIGINALI"

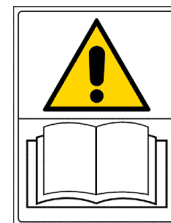

INDICE

1. DESCRIZIONE GENERALE	3
DESTINAZIONE D'USO	3
DESCRIZIONE DEL PRODOTTO.....	3
GARANZIA.....	3
2. SICUREZZA.....	4
NORME DI SICUREZZA	4
ZONE A RISCHIO RESIDUO.....	5
POSIZIONAMENTO ETICHETTE	5
3. USO DEL DISPOSITIVO RETE	
RIBALTA VERTICALE E SUO FUNZIONAMENTO.....	6
GENERALITÀ	6
CARATTERISTICHE TECNICHE	6
ISTRUZIONI DI MONTAGGIO	11
4. MANUTENZIONE-PULIZIA-	
LUBRIFICAZIONE-SMALTIMENTO	32
MANUTENZIONE	32
PULIZIA E LUBRIFICAZIONE	32
SMALTIMENTO.....	32

CONFORME ALLA DIRETTIVA 2001/95/CE
NORME UNI EN 1129-1



Pessotto Reti srl
Viale delle Industrie, 36 - Albina di Gaiarine (TV) - Italia
Tel. +39 0434 758734 - Fax +39 0434 758533
info@pessottoreti.com - www.pessottoreti.com





USER GUIDE “ORIGINAL INSTRUCTIONS”



INDEX

1. GENERAL DESCRIPTION	7
USE	7
PRODUCT DESCRIPTION	7
GUARANTEE	7
2. SAFETY	8
SAFETY STANDARD	8
RESIDUAL RISK AREAS	9
LABELS.....	9
3. USE OF THE BED SYSTEM	
VERTICAL HIDE-AWAY AND FUNCTIONING	10
GENERAL DATA	10
TECHNICAL FEATURES	10
ASSEMBLING INSTRUCTIONS	11
4. MAINTENANCE - CLEANING	
LUBRIFICATION - DISPOSAL	33
MAINTENANCE	33
CLEANING AND LUBRIFICATION	33
DISPOSAL.....	33

ENGLISH

IN ACCORDANCE WITH STANDARD 2001/95/CE

UNI EN 1129-1



Pessotto Reti srl
Viale delle Industrie, 36 - Albina di Gaiarine (TV) - Italia
Tel. +39 0434 758734 - Fax +39 0434 758533
info@pessottoreti.com - www.pessottoreti.com





VI PREGHIAMO DI LEGGERE ATTENTAMENTE LE ISTRUZIONI E LE NORME CONTENUTE IN QUESTO FASCICOLO



1. DESCRIZIONE GENERALE

DESTINAZIONE D'USO

Il "sistema a ribalta verticale manuale" permette di portare una rete da letto posta in verticale all'interno di un cassone armadio, in posizione orizzontale per poterlo utilizzare come letto aggiunto nella stanza nella più assoluta rapidità, evitando sforzi ingiustificati all'utente.

Prima di usare l'armadio letto, l'utente deve accertarsi del suo buono stato e del buono stato degli accessori presenti, attraverso un esame visivo.

Prima di usare l'armadio letto, l'utente deve accertarsi che sul piano rete siano presenti solo ed esclusivamente materasso e coperte.

DESCRIZIONE DEL PRODOTTO

Il sistema letto a ribalta verticale manuale ammortizzato è composto da:

- una coppia di piastre in ferro verniciato
- cerniere per movimentare la pediera
- una rete da letto comprensiva di doghe di supporto per il materasso
- agganci per collegare l'anta fissa e la pediera
- viti bulloni rondelle e particolari in nylon atti al suo funzionamento

GARANZIA

La Ditta **PESSOTTO RETI** garantisce i propri prodotti per un periodo di utilizzo pari a due anni dalla data di acquisto.

Sono escluse dalla garanzia le parti relative a componenti commerciali per le quali vale la garanzia del fabbricante originario.

La garanzia verrà riconosciuta solamente se l'apparecchiatura è stata utilizzata correttamente seguendo le istruzioni contenute nel presente manuale. Si declina ogni responsabilità per uso improprio della stessa.

L'uso di questo prodotto è semplice: **prima di installarlo e utilizzarlo è necessario leggere attentamente questo libretto.** In esso potrà trovare le corrette indicazioni per l'ottimale installazione, utilizzazione e manutenzione del prodotto.

E' molto importante che questo libretto istruzioni sia conservato insieme al prodotto in caso di trasferimento ad altro utente.

Questo prodotto è stato concepito per l'utilizzo non professionale da parte di privati all'interno di abitazioni. L'apparecchio non è destinato ad essere usato da persone (bambini compresi) le cui capacità fisiche, sensoriali o mentali siano ridotte, oppure con mancanza di esperienza o di conoscenza, a meno che esse abbiano potuto beneficiare, attraverso l'intermediazione di una persona responsabile della loro sicurezza, di una sorveglianza o di istruzioni riguardanti l'uso dell'apparecchio.



I bambini devono essere sorvegliati per sincerarsi che non giochino con l'apparecchio. La messa in servizio l'installazione e/o la regolazione/messa a punto del prodotto deve essere eseguita a regola d'arte da installatori competenti e qualificati, nel rispetto di quanto riportato nel presente manuale.

N.B. PESSOTTO RETI declina ogni responsabilità per la mancata osservanza di tali avvertenze.

2. SICUREZZA

NORME DI SICUREZZA

Il rispetto delle norme di sicurezza mette l'utilizzatore in condizioni di lavorare produttivamente senza pericolo di arrecare danni a se stesso e agli altri.

-  È vietato l'utilizzo del sistema letto a ribalta senza la presenza del materasso sul piano rete.
-  È vietato l'utilizzo del sistema letto a ribalta per motivi diversi da quelli precedentemente descritti nella destinazione d'uso.
-  Un'installazione non corretta o non effettuata da personale specializzato può provocare distacchi, rotture, disfunzioni del prodotto con possibili danni a persone, cose o animali. **RISPETTARE RIGOROSAMENTE TALE PRESCRIZIONE.**

Prima di iniziare ad utilizzare il sistema letto a ribalta l'utente deve essere a conoscenza delle funzioni del prodotto e delle caratteristiche tecnico funzionali dello stesso, acquisite da un'accurata e completa visione del contenuto del presente manuale.

È vietata la manomissione o sostituzione di parti del prodotto non espressamente autorizzate dalla ditta Pessotto Reti srl.

L'uso di accessori o parti di ricambio diversi da quelli raccomandati e/o riportati nel presente libretto comporta un uso improprio e pericoloso del prodotto.

Qualsiasi intervento di modifica del prodotto non espressamente autorizzata dalla ditta Pessotto Reti srl solleva la stessa da qualsiasi responsabilità civile e penale.

-  È severamente proibito rimuovere qualsiasi dispositivo di sicurezza e di protezione (etichette) presente sul prodotto; verificare periodicamente la posizione fortuita sul meccanismo di coperte o altro

Prima di iniziare qualsiasi attività di manutenzione, pulizia o riparazione sul prodotto, si deve aver letto e compreso tutte le informazioni tecniche contenute nel presente manuale.

Qualsiasi operazione di manutenzione e riparazione deve essere eseguita da personale qualificato.

-  **ATTENZIONE !!!**
Non posizionare mai il prodotto in vicinanza di fonti di calore. Posizionare e bloccare in modo stabile il sistema letto a ribalta tra il cassone e il piano rete.

La zona di movimentazione del letto deve essere mantenuta sgombera da oggetti che possono limitare un libero movimento.

Le istruzioni e le regole contenute nel presente manuale devono essere sempre rispettate.

ZONE A RISCHIO RESIDUO

In alcune zone del sistema letto a ribalta sono presenti rischi residui che non è stato possibile eliminare in fase di progettazione.

Ciascun utilizzatore deve conoscere i rischi residui presenti in questo prodotto al fine di prevenire eventuali incidenti.

Questi pericoli sono qui elencati:



1) PERICOLI DI SCHIACCIAMENTO Durante la movimentazione del piano rete esistono rischi residui di schiacciamento delle mani tra le parti mobili del meccanismo e la struttura fissa del letto (rischio residuo di schiacciamento)

2) ACCERTARSI che nelle zone di appoggio della rete o sopra la rete stessa non siano presenti persone, animali o cose che possano collidere con movimentazione.

POSIZIONAMENTO ETICHETTE

Il sistema letto a ribalta verticale manuale e' dotato dei seguenti segnali di sicurezza e identificazione:



La segnaletica serve ad informare gli utenti dei rischi eventuali presenti durante la fase di movimentazione



I segnali adesivi e le targhette applicate non devono essere staccati, manomessi o distrutti.

POSIZIONE	ETICHETTE	DESCRIZIONE
Sulla rete in movimentazione		Attenzione Schiacciamento mani

3. USO DEL DISPOSITIVO RETE RIBALTA VERTICALE E SUO FUNZIONAMENTO

GENERALITÀ

Il sistema letto a ribalta verticale manuale è stato creato tendo conto delle esigenze di avere un letto aggiuntivo a seconda delle necessità nella più assoluta rapidità evitando sforzi ingiustificati all'utente.

MECCANISMO MANUALE

Il **movimento manuale a ribalta verticale** viene effettuato tramite due molle a gas poste ai lati della struttura che inclinano la rete e da altre due molle a gas che inclinano il pannello superiore che in fase di movimento diventa la pediera del letto (pag.31)

CARATTERISTICHE TECNICHE

Misure rete materasso	Rete 1420 mm Materasso 1400x2000 mm	Rete 1620 mm Materasso 1600x2000 mm	Rete 1820 mm Materasso 1800x2000 mm
Peso rete	29Kg	32Kg	35Kg
Peso materasso medio	25Kg	28Kg	32Kg
Peso anta superiore	8,2Kg	9,5Kg	10,8Kg
Peso anta inferiore	33.5Kg	38Kg	42,4Kg
Dimensioni interne vano	2175x1505 x360 mm	2175x1705 x360 mm	2175x1905 x360 mm

ISTRUZIONI DI MONTAGGIO

Prima e dopo il montaggio verificare che il pavimento di appoggio ed il muro, in cui è fissato il prodotto, abbiano caratteristiche adeguate e che i dispositivi di fissaggio forniti ed impiegati siano in grado di resistere alle forze generate.



ALL INSTRUCTIONS OF THIS BOOKLET SHALL BE CAREFULLY READ!!!



1. GENERAL DESCRIPTION

USE

The manual vertical hideaway bed system allows to bring the bedspring from its vertical position inside the cabinet in a horizontal position, to be used as a bed, in an absolutely quick and easy way, with very low efforts.

Before using the hideaway bed, the user must be sure of its good condition and the good condition of its accessories.

Before using the hideaway bed, the user must make sure that on the sleeping surface there is only the mattress and bed linens.

PRODUCT DESCRIPTION

The bed system is composed by following items:

- left and right metal plates with epoxy powder coating
- hinges to move footboard
- a slatted bedspring
- brackets for door and footboard connection
- hardware fittings

GUARANTEE

PESSOTTO RETI warrants its products for a period of 2 years from the date of purchase. This warranty excludes commercial components. These parts are guaranteed by their original manufacturer.

The guarantee is valid only for appliances that have been installed and used correctly by following all the guidelines of this brief and the “Fixing instructions”.

Responsibility for any misuse is disclaimed.

This product's use is very simple: **before installing and using it, it's mandatory to carefully read the booklet.** Herein you'll find all correct advices for an optimal installation, use and maintenance of the product.

It's important that the booklet is kept together with the product.

This product has been developed for a non-professional use by private persons in households. Its use is not intended to be used by people (children included) whose physical, sensorial or mental capacities are weak, or do not have any experience or knowledge, unless they have been taught by a person that's responsible for their safety. Children shall be surveyed and are not allowed to play with the device.



The installation and/or adjustments of the product shall be carried out in a workmanlike way only by qualified installers, in accordance with all the installation rules of this brief.

Remarks: No liability is assumed by PESSOTTO RETI in failure to comply with the given advices.

2 . SAFETY

SAFETY STANDARD

Compliance with the safety standards puts the user in terms of working productively, without danger of harm to himself and to others.

-  **It's forbidden to use the product without any mattress on the bedspring surface.**
-  **It's forbidden to use the bed for a different use, than the one described previously in section USE.**
-  **Non correct installation or not made by specialized craftsmen, may cause detachments, breaking or dysfunctions with possible damages to persons, things or animals. All given instructions have to be strictly observed.**

Before starting to use the product the users shall be aware of its functions and its technical features, learnt through an accurate and complete reading of the present user's guide.

Tampering or replacement of bed parts that are not authorized by Pessotto Reti, are not allowed.

The use of accessories or spare parts other than those recommended by the supplier, present a non proper and hazardous use of the product.

Any modification of the product not expressly approved by the company Pessotto Reti releases the company from any civil or penal liability.

-  **It's strictly forbidden to remove any safety device and protection (labels) on the set; periodically check the incidental position on the mechanism of blankets or else.**
Before starting any maintenance, repair work or cleaning the operator must have read and understood all technical information contained in this guide.
Any maintenance and repair shall be performed by qualified personnel only.

-  **WARNING !!!**
Never place the product near any heat sources.
Position and lock the bed system to be maintained clear of objects that may hinder its movement.

The instructions and rules contained in this manual must be observed at all times.

RESIDUAL RISK AREAS

In some areas of the product there are some residual risks that couldn't be avoided in designing.

Each user has to be aware of the residual risks of this product in order to avoid possible accidents.

These dangers are listed below:



1) HAZARDS OF CRUSHING

While moving the bedspring there are residual risks of crushing hands between the moving parts of the mechanism and the fixed structure of the bed.

2) MAKE SURE that the area of the bedspring or on the bedspring itself there are no people, animals or things that could collide with its movement.

PLACING OF LABELS

On the product following safety or identification labels could be placed:

 The labels are to inform the users of possible risks during the mechanism's motion.

 No stickers or plates shall be removed, tampered or destroyed.

POSITION	LABEL	DESCRIPTION
On bedspring during motion.		Caution: Hand crushing

3. USE OF THE VERTICAL HIDEAWAY BED AND ITS FUNCTION

GENERAL

The vertical manual hideaway bedsystem has been developed by keeping in mind to have an extra bed, according to the needs, in a absolutely quick way, avoiding all unjustified efforts of the user.

MANUAL MECHNANISM

The manual hideaway bed's movement happens by means of two gas springs put on the sides of the structure, and recline the bedspring and by other two gas springs which recline the upper panel, that becomes the bed's footboard. (pag.31)

TECHNICAL FEATURES

Bedspring/ mattress size	Bedspring 1420mm Mattress 1400x2000 mm	Bedspring 1620mm Mattress 1600x2000 mm	Bedspring 1820mm Mattress 1800x2000 mm
Bedspring weight	29Kg	32Kg	45Kg
Mattress average weight	25Kg	28Kg	32Kg
Footboard panel weight	8,2Kg	9,5Kg	10,8Kg
Front panel weight	33,5Kg	38Kg	42,4Kg
Internal size of the cabinet	2175x1505 x360 mm	2175x1705 x360 mm	2175x1905 x360 mm

FIXING INSTRUCTIONS

Before and after assembly, check that the floor and the wall where the product is installed have proper characteristics and that the fasteners provided and used are able to withstand at generated force.

ISTRUZIONI DI MONTAGGIO / ASSEMBLY INSTRUCTIONS

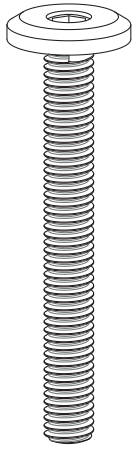

A
M6x55

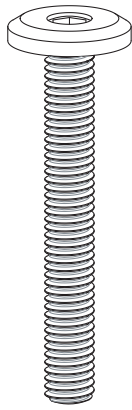

B
M6x45

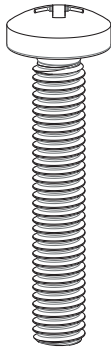

C
M6x35

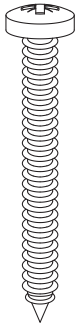

D
M4x35

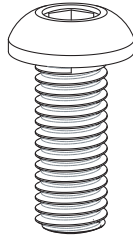

E
M8x20

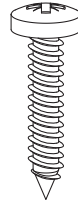

F
M4x20

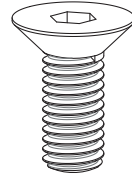

G
M6x15

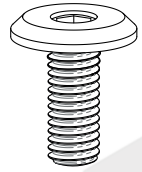

H
M6x15

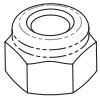

I M6



J M6

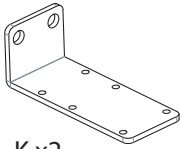

K x2

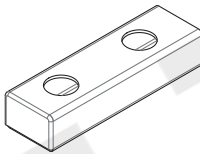

L x2

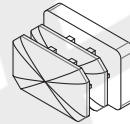

M x2

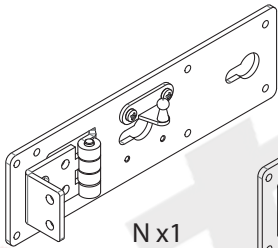

N x1

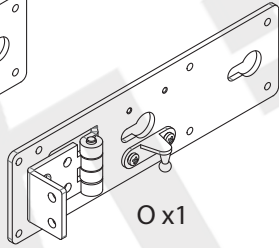

O x1

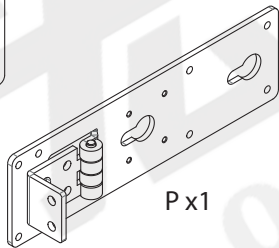

P x1

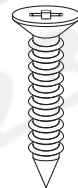

Q
M4x18

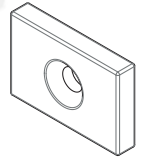

R x2

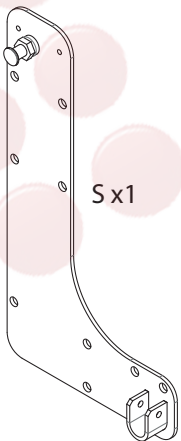

S x1

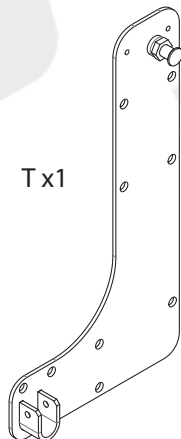

T x1

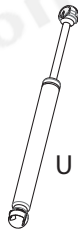

U x2

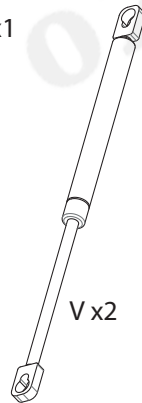

V x2

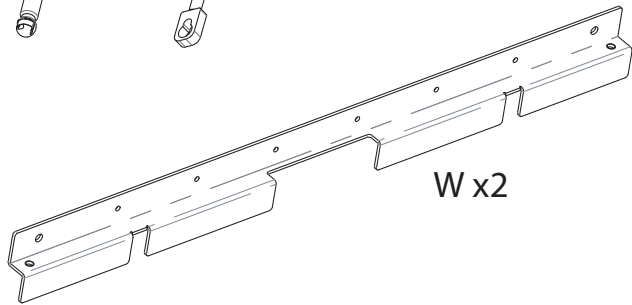

W x2

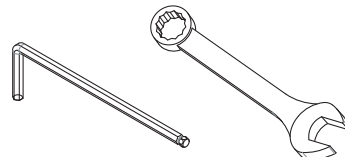
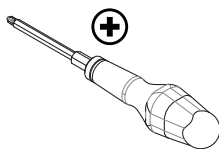
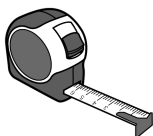
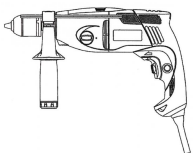

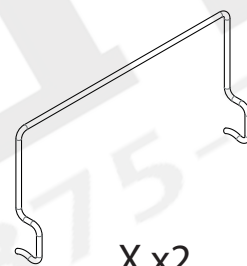

X x2

STEP 01

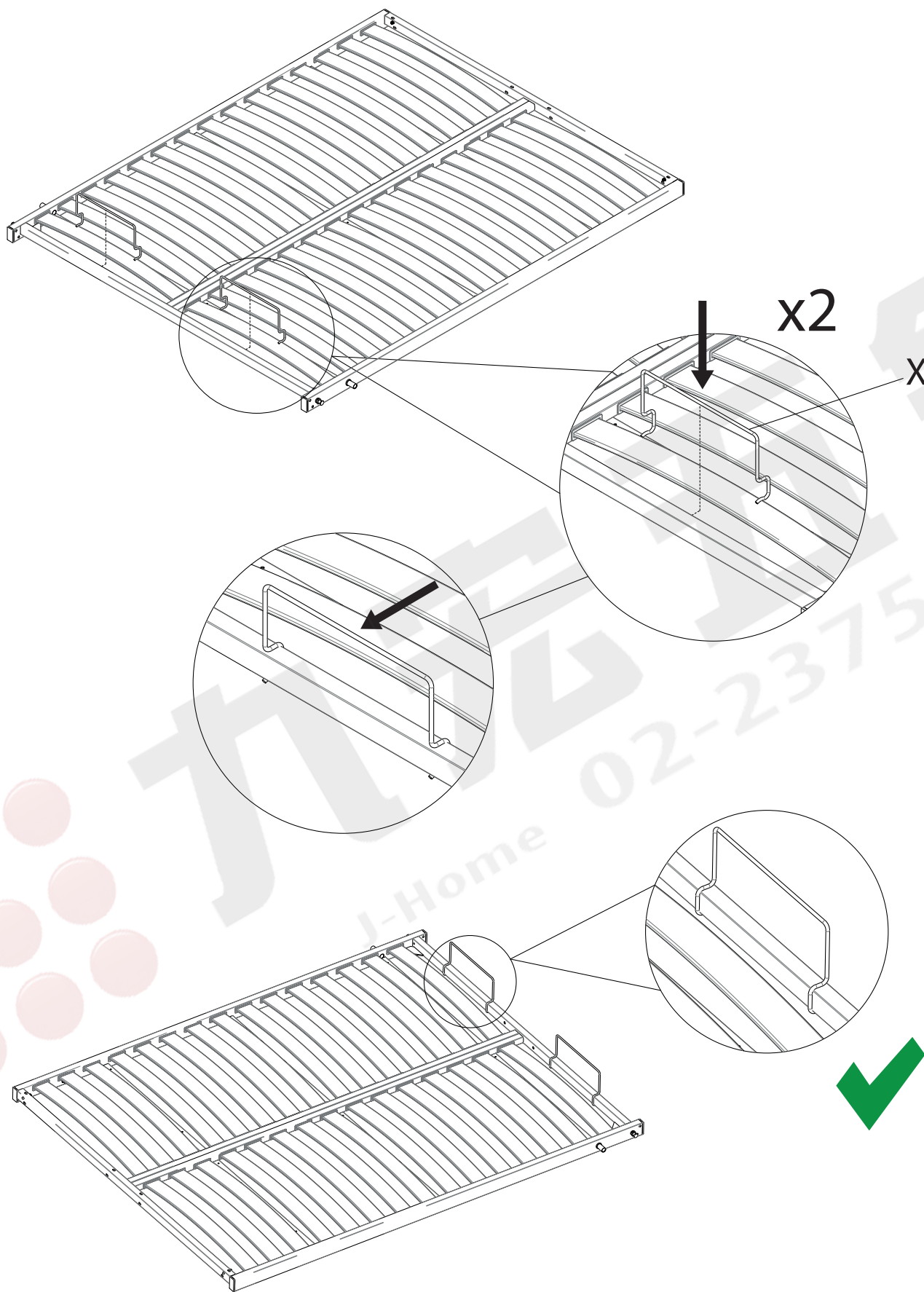

STEP 02

VITI NON FORNITE
SCREWS NOT PROVIDED

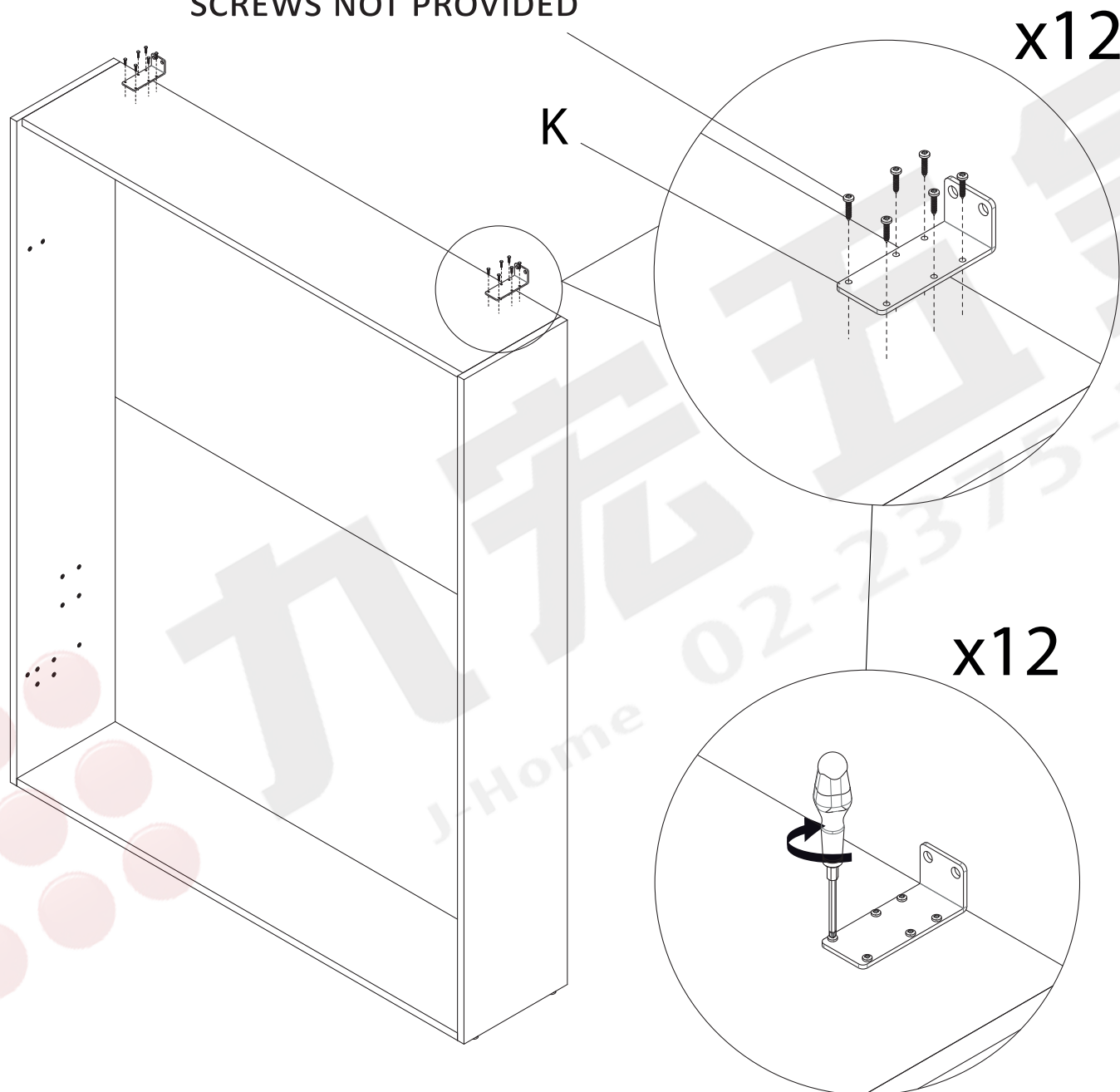

STEP 03



Nota: l'accoppiamento vite, tassello, muro deve avere una forza di tenuta superiore a **200 Newton** su singola vite; la forza di tenuta di ogni punto di fissaggio deve essere superiore a 400N. Accertarsi con il proprio fornitore la tipologia di tasselli da usare ed installare nel rispetto delle istruzioni date dallo stesso.

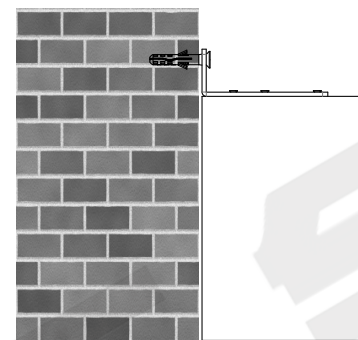
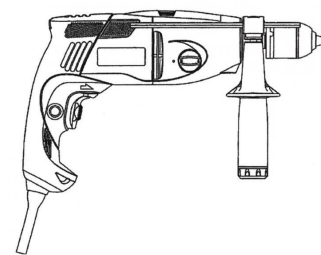

Remarks: the combination screws, dowel, wall must have higher seal strength 200 Newton on single screw. The seal strength of each single fixing point must be higher than 400 Newton. Check with the supplier on what kind of dowels are to be used and install to respect the instructions.

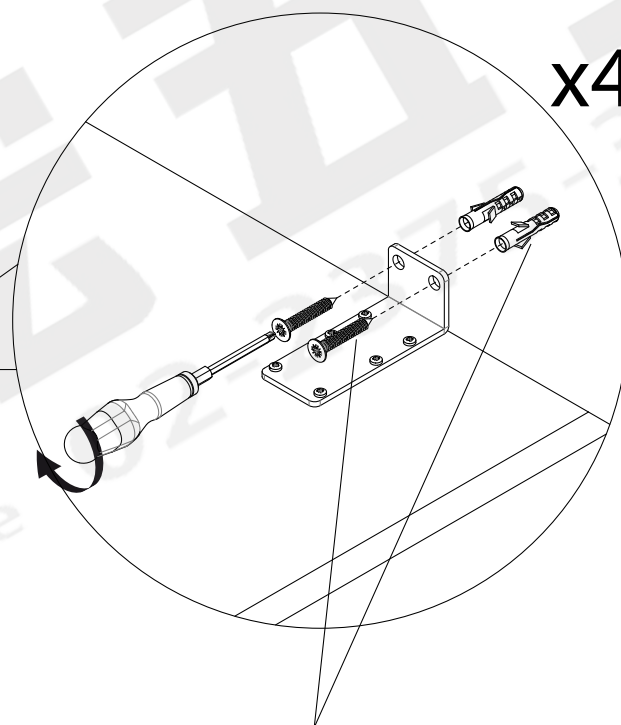
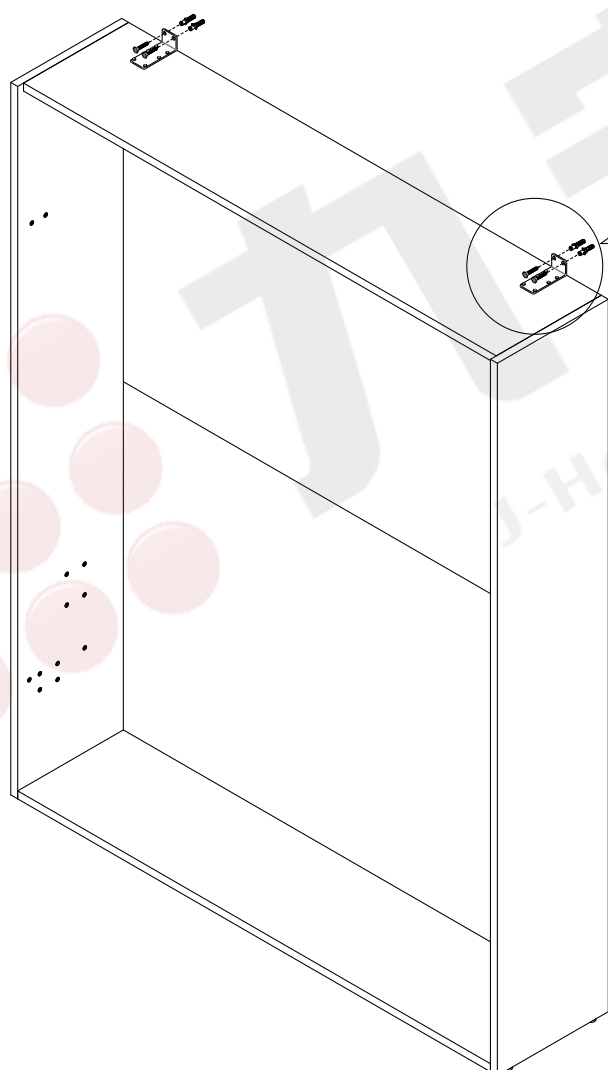

VITI NON FORNITE
SCREWS NOT PROVIDED

STEP 04

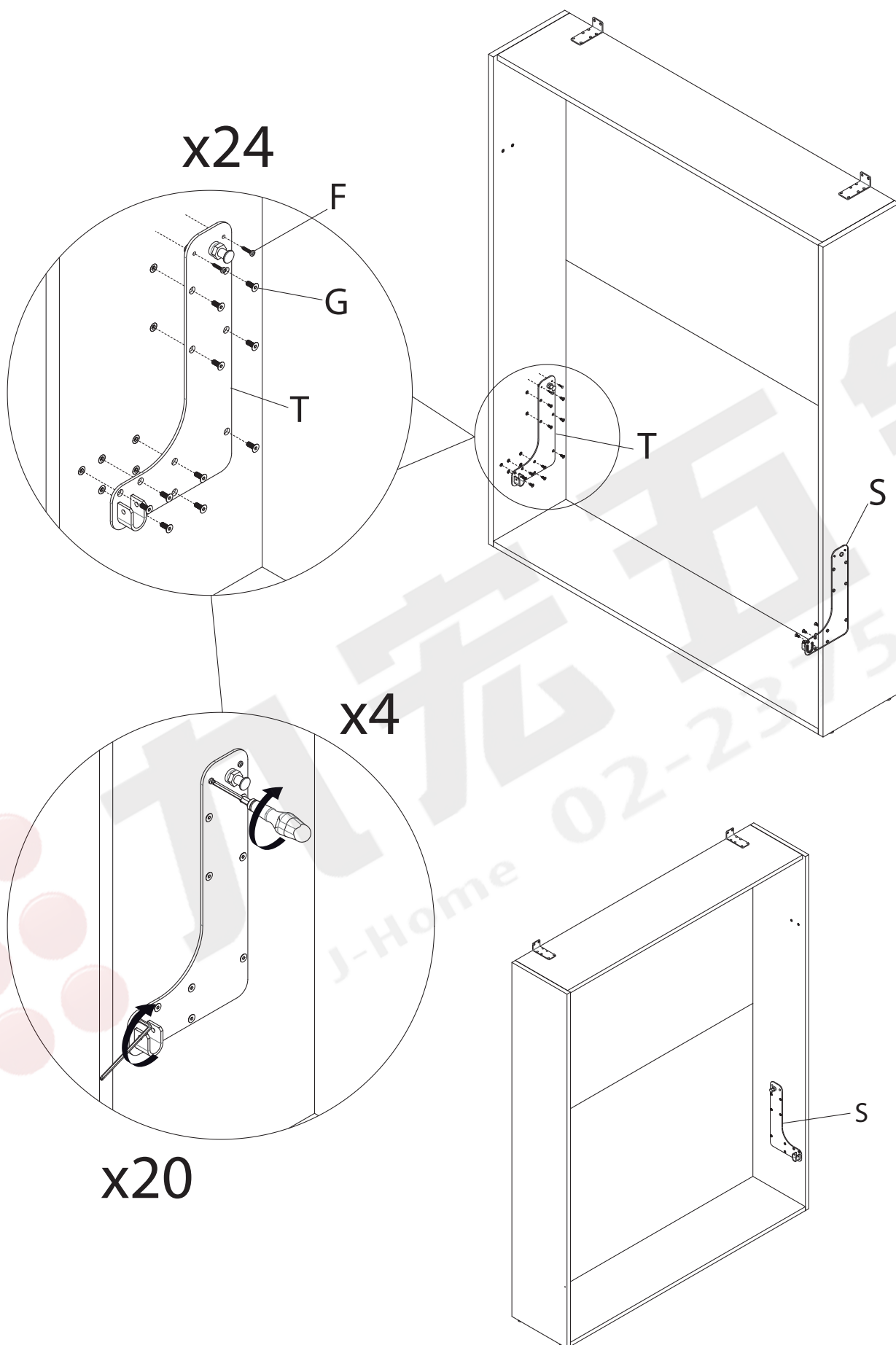

STEP 05

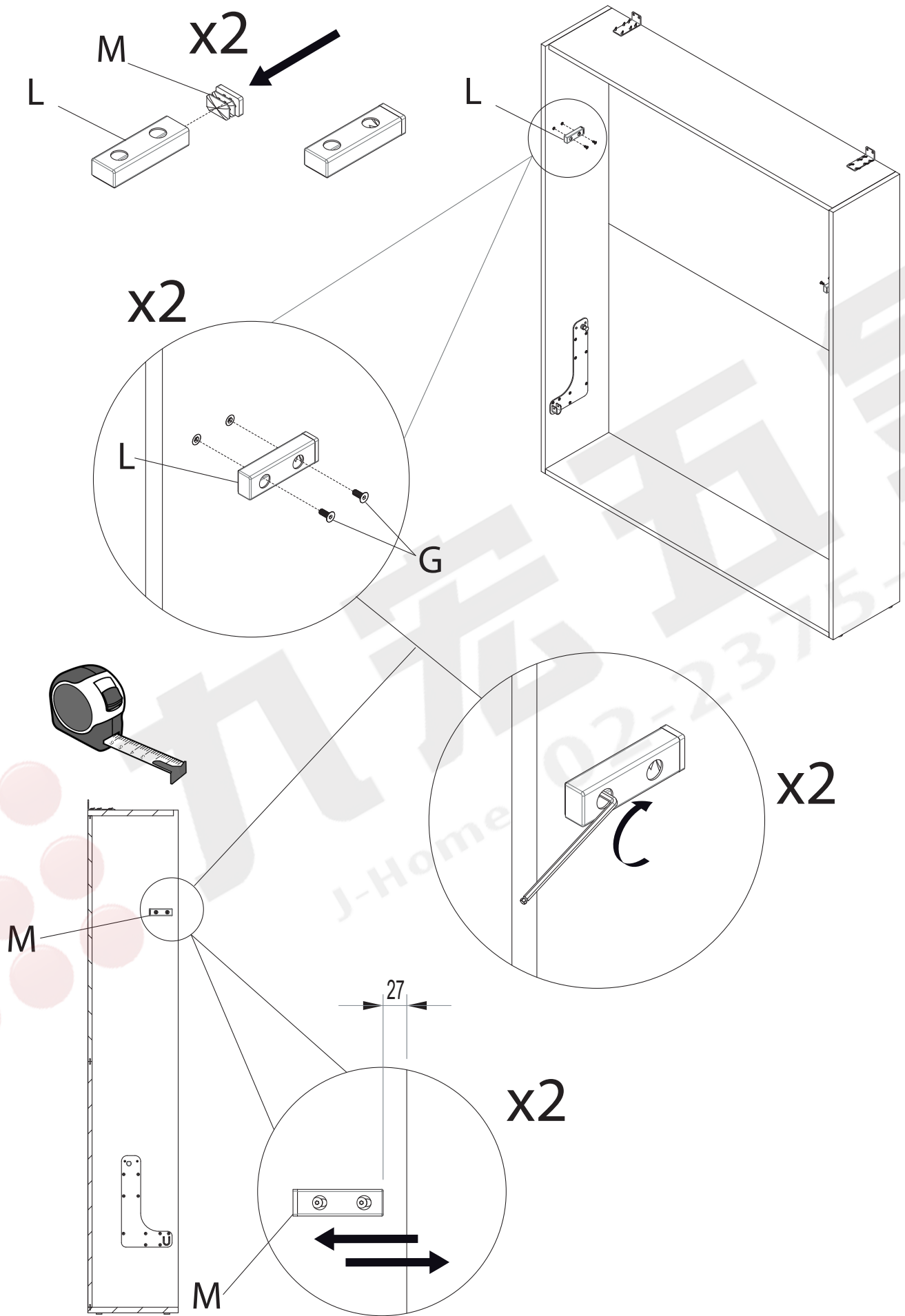

STEP 06

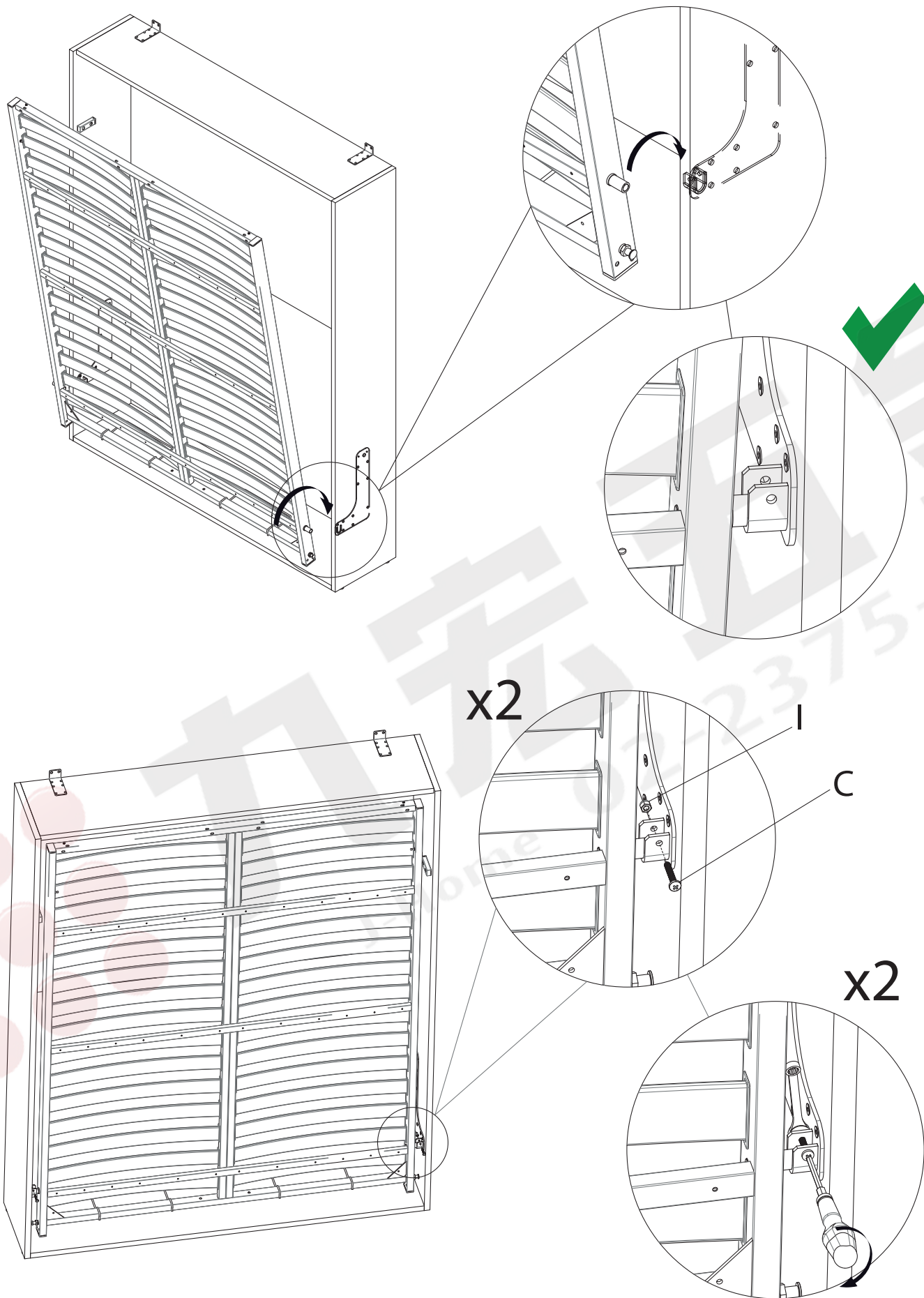

STEP 07

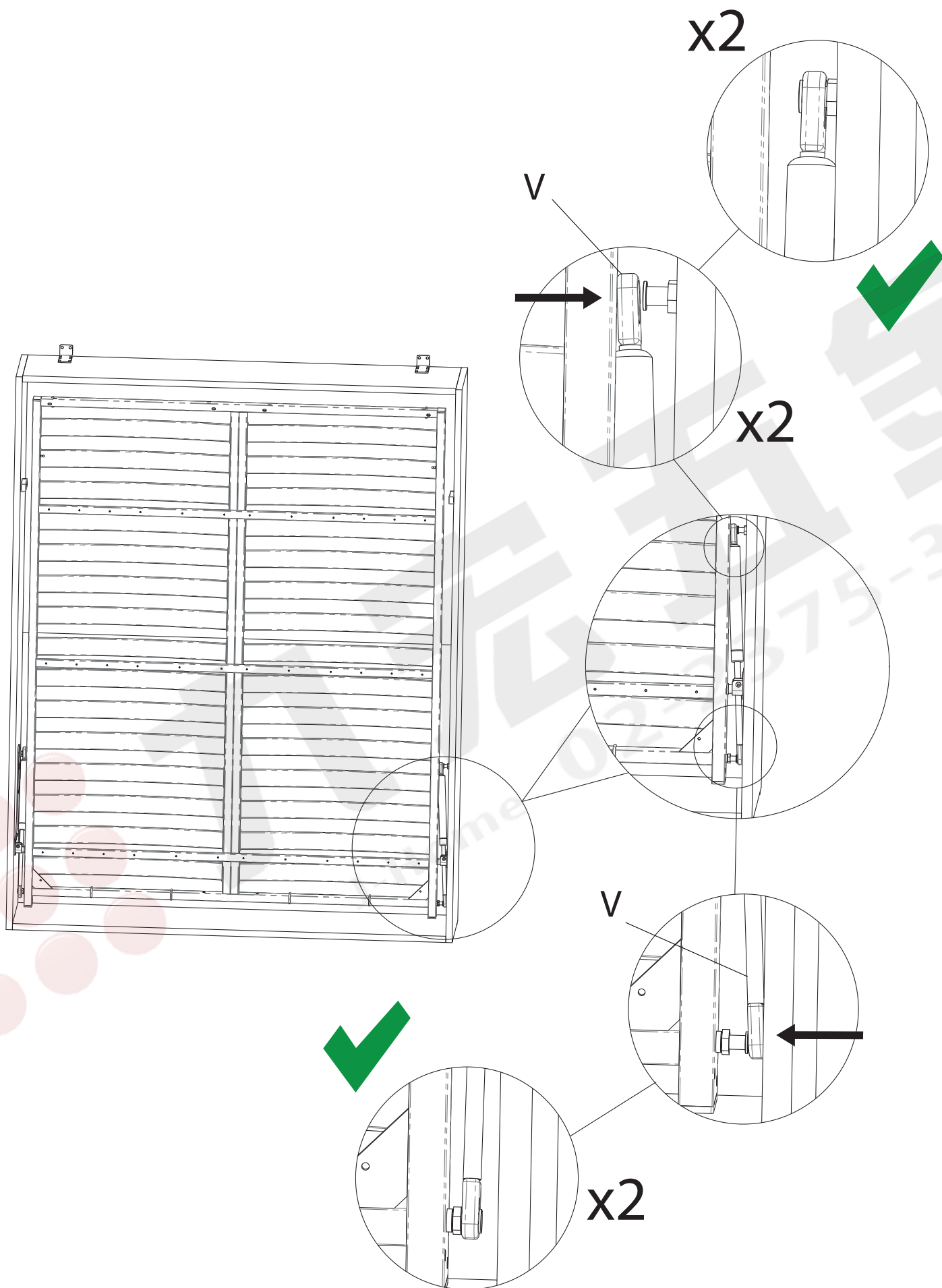

STEP 08

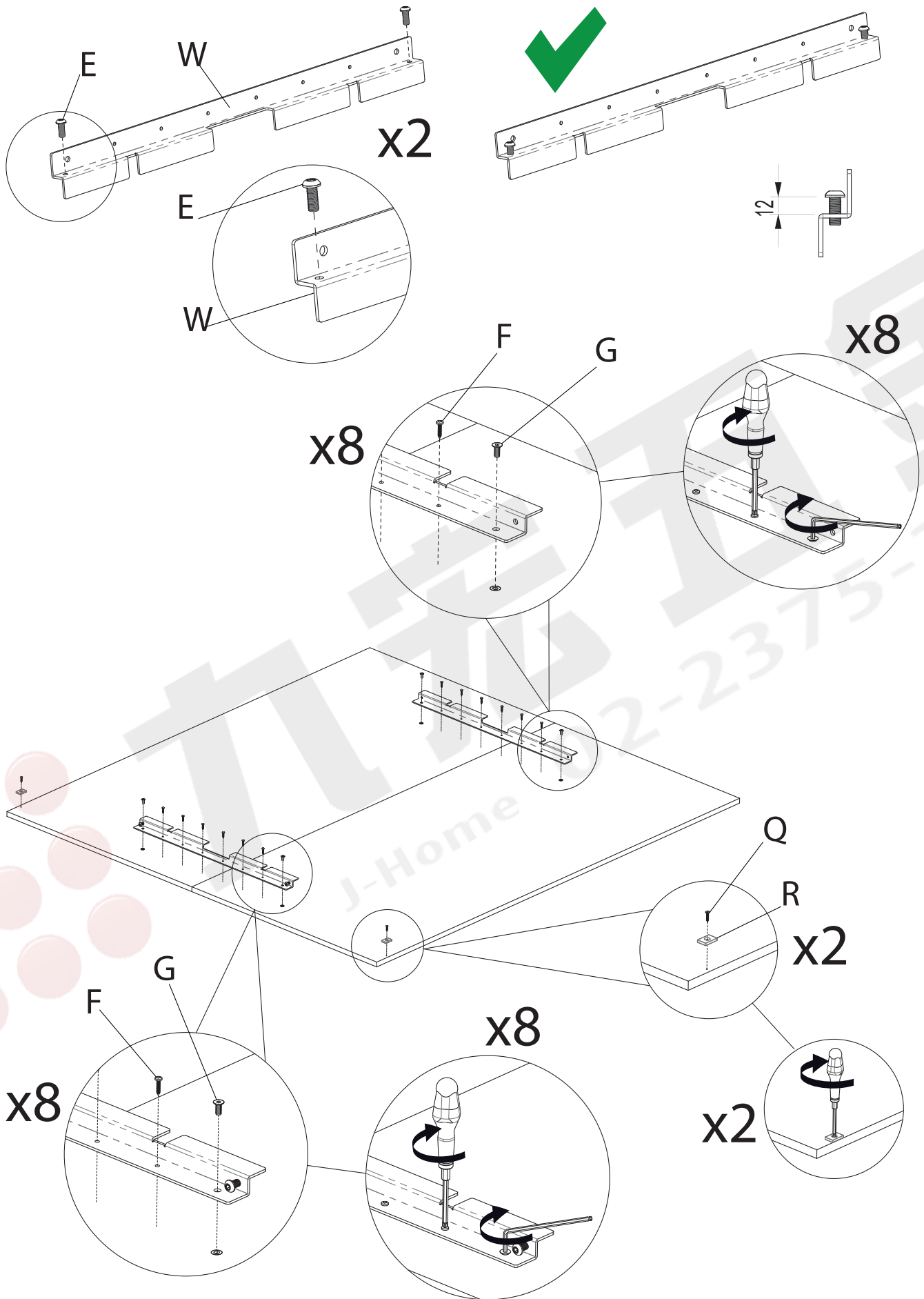

STEP 09

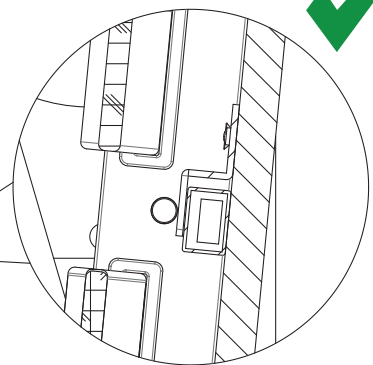
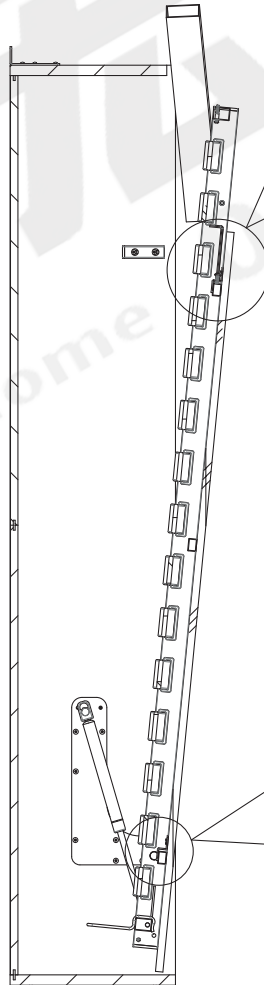
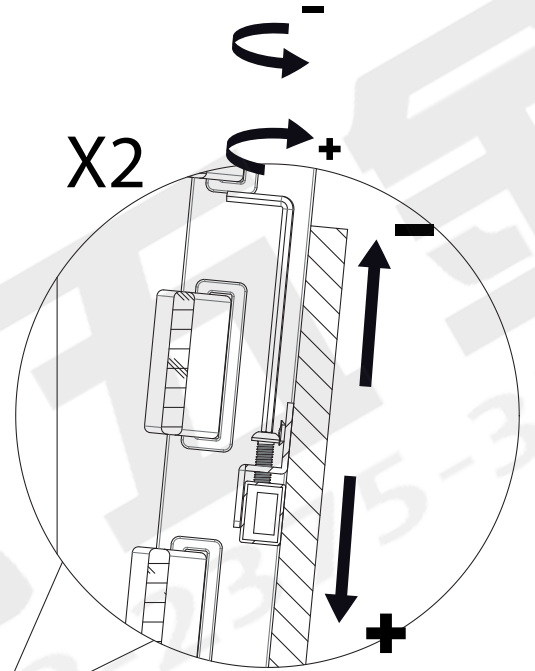
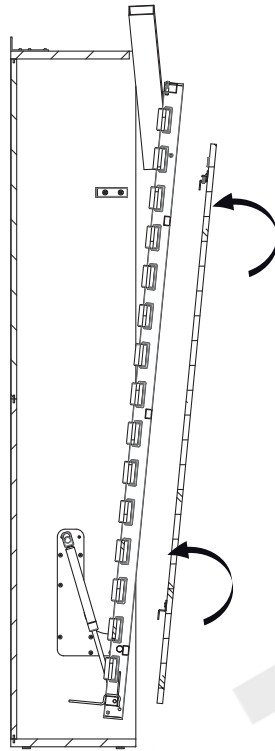
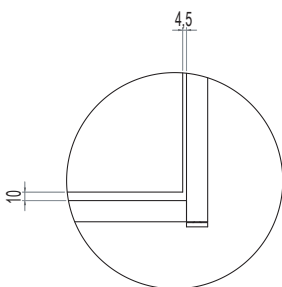
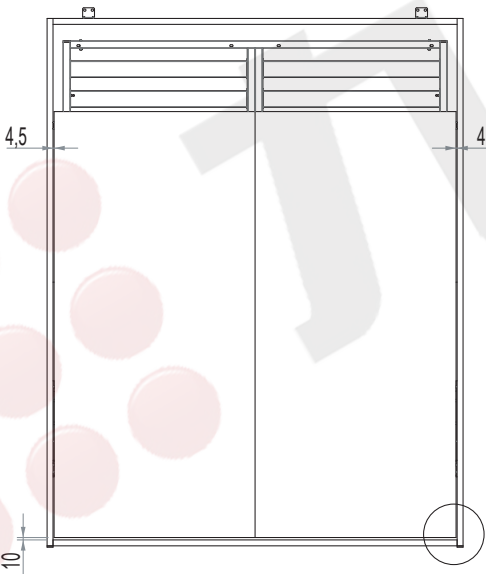
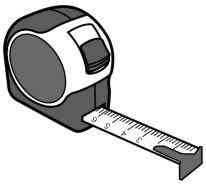
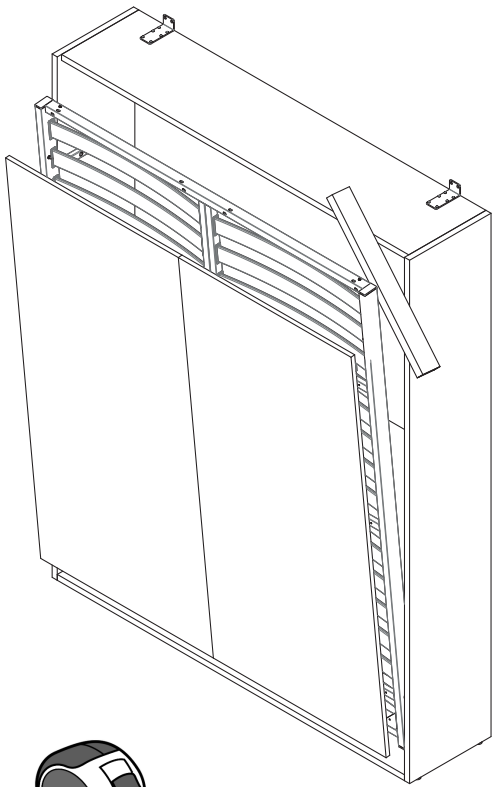

STEP 10

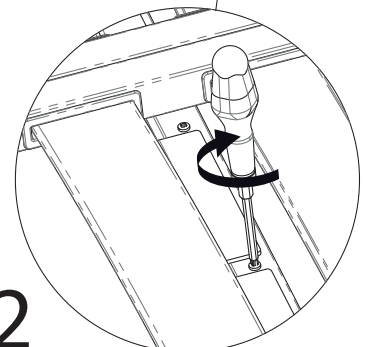
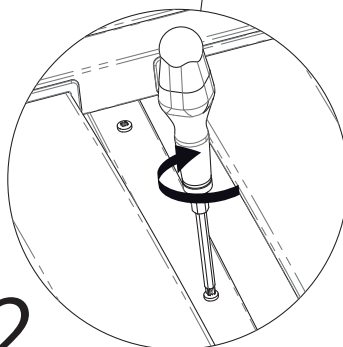
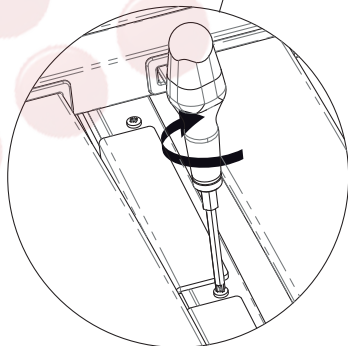
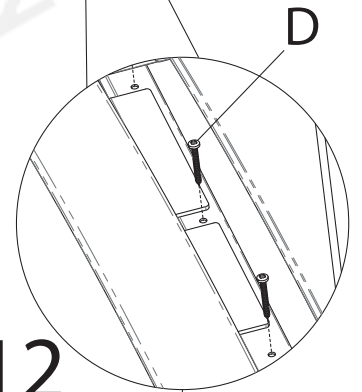
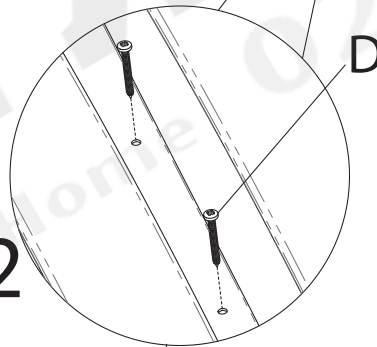
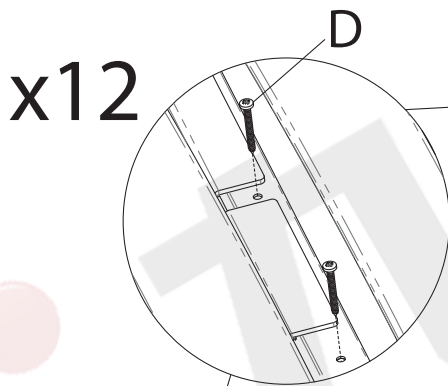
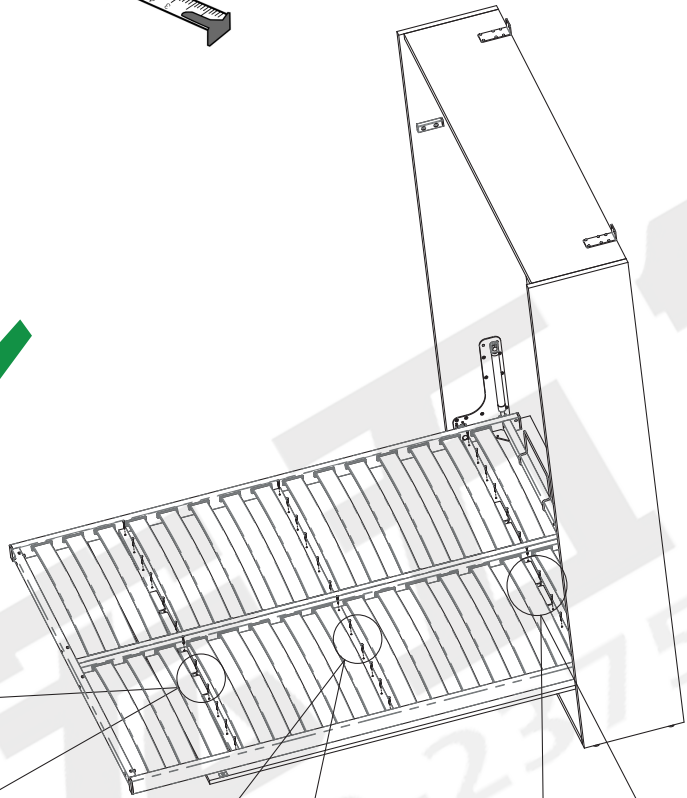
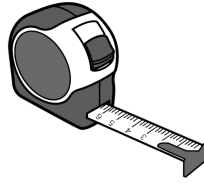
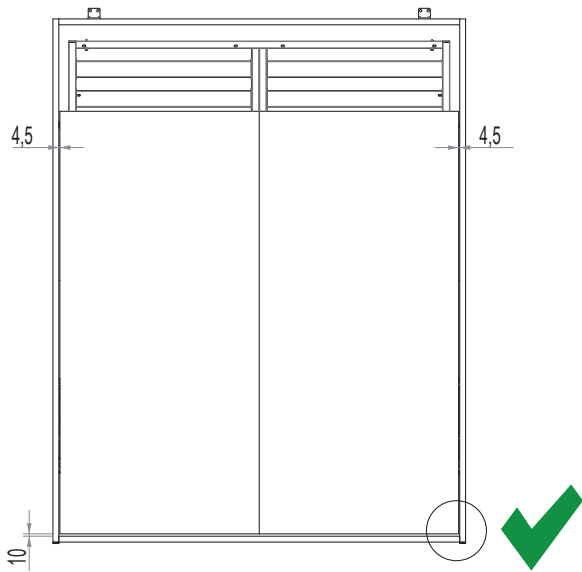

STEP 11

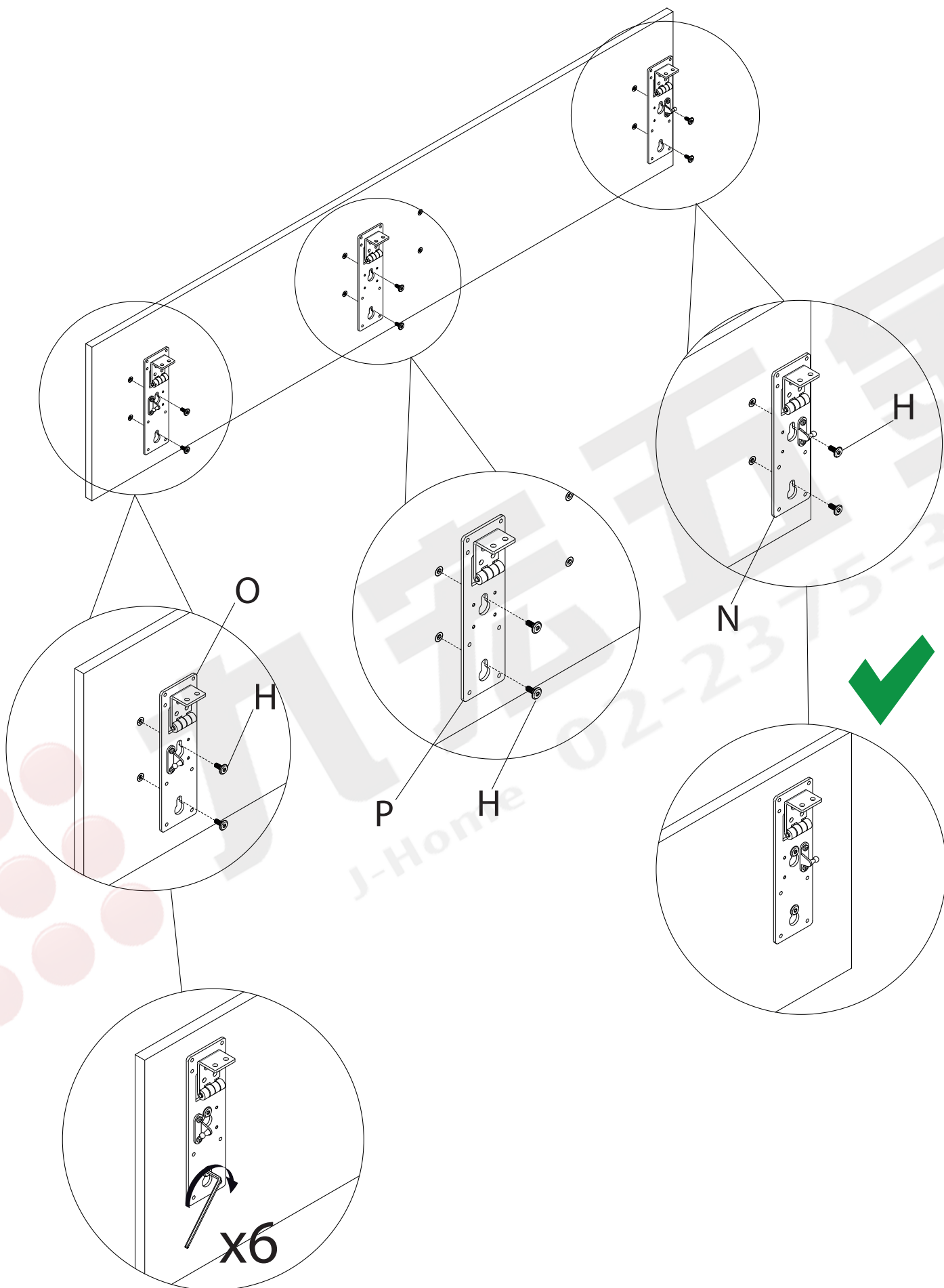

STEP 12

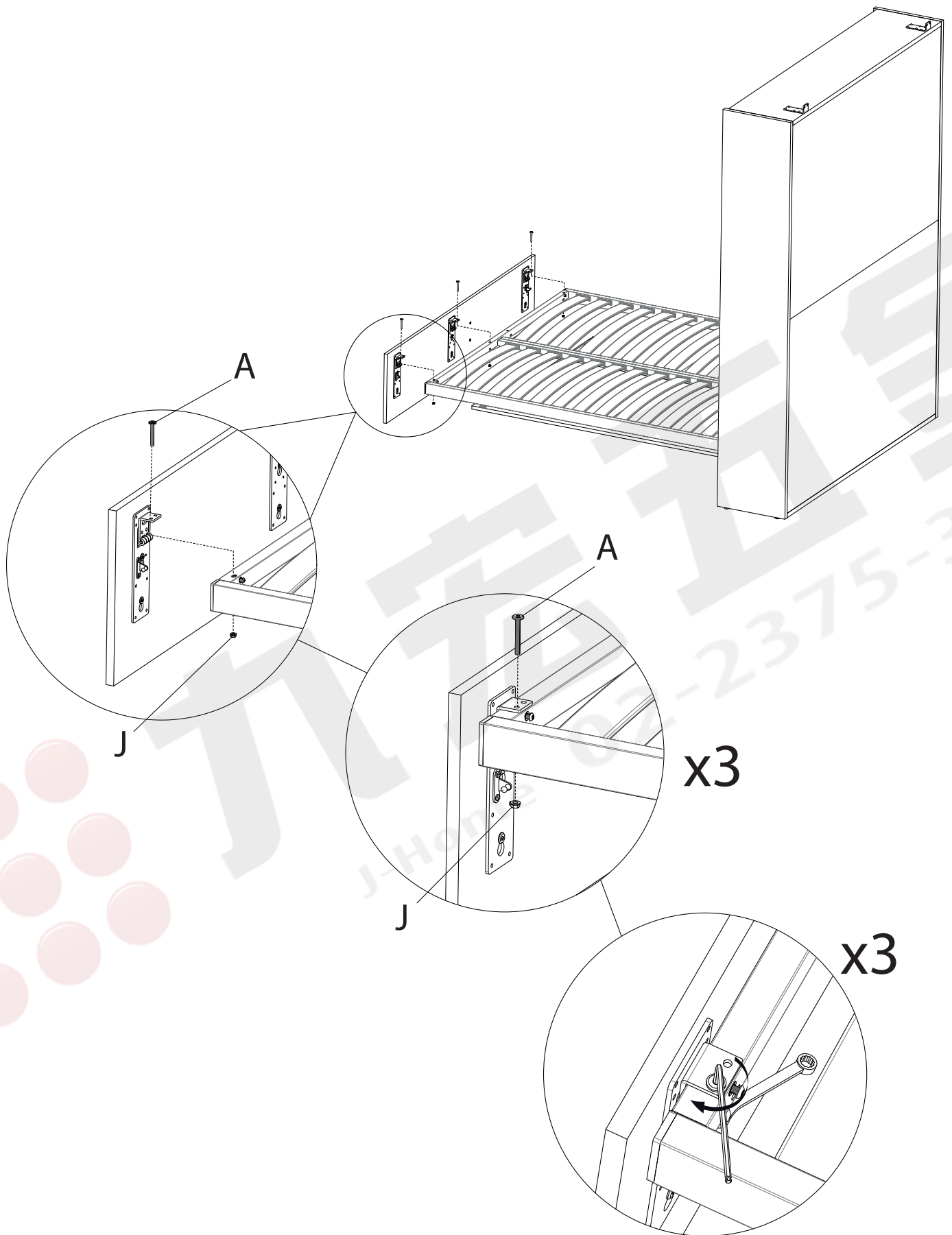

STEP 13

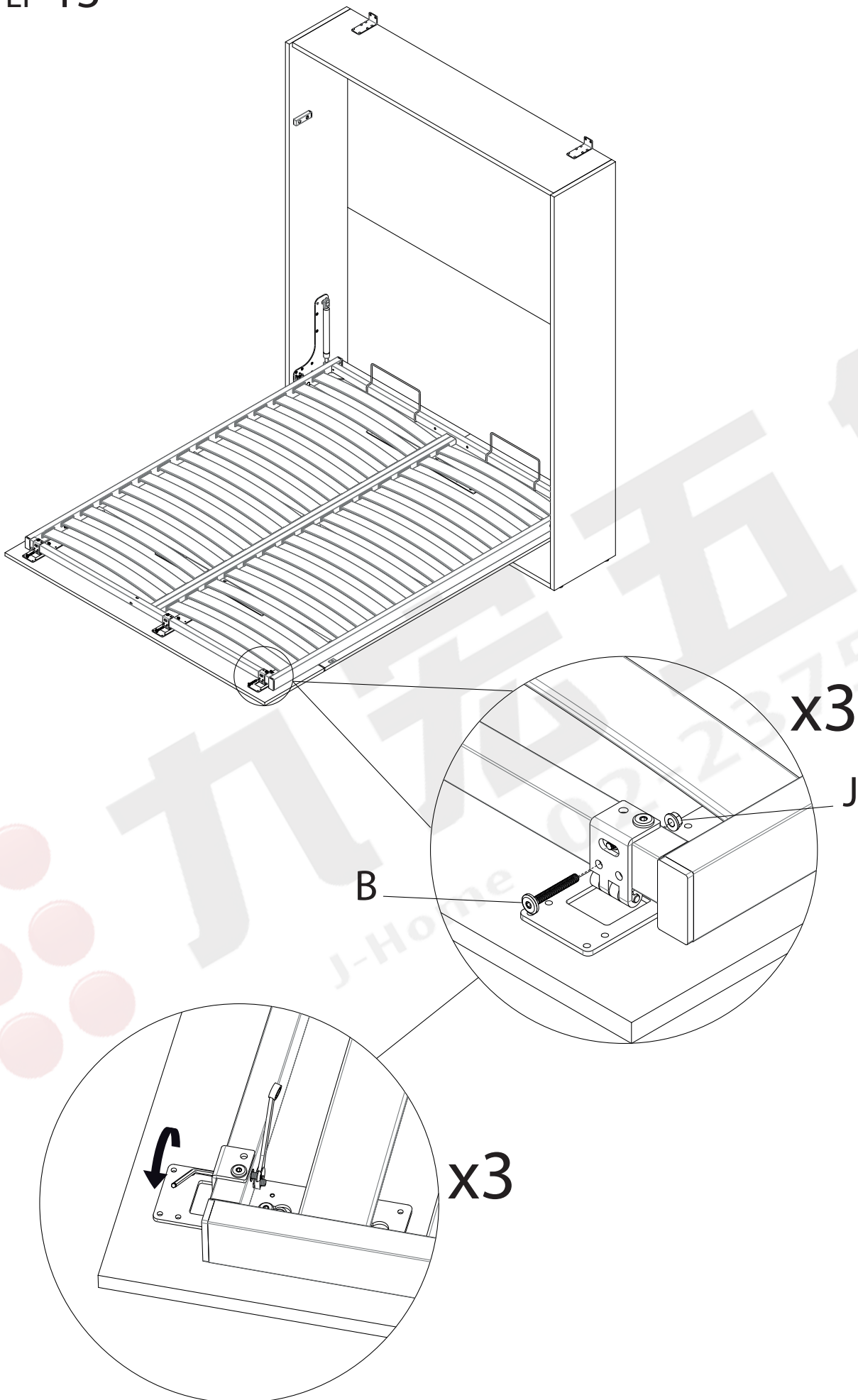

STEP 14

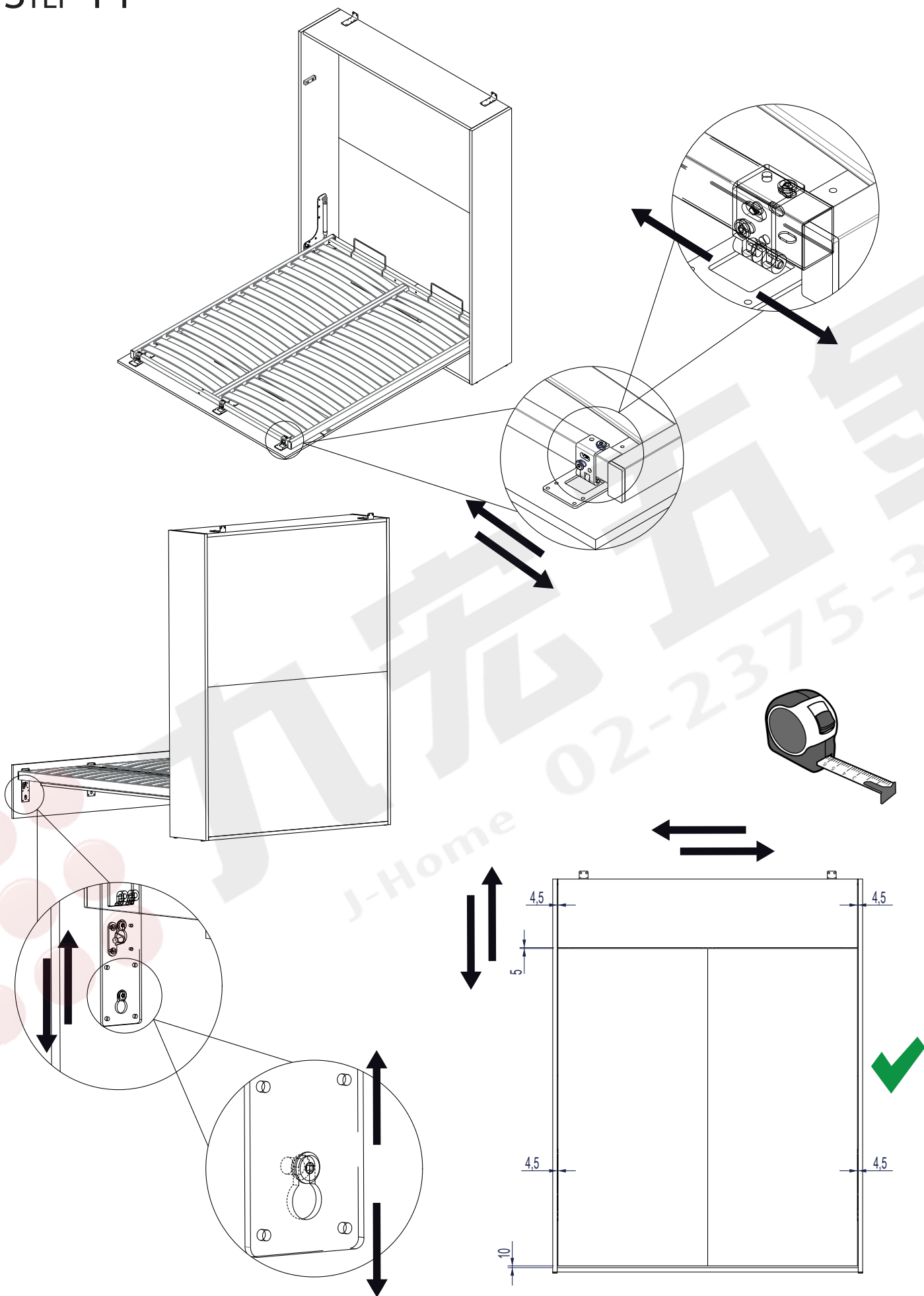

STEP 15

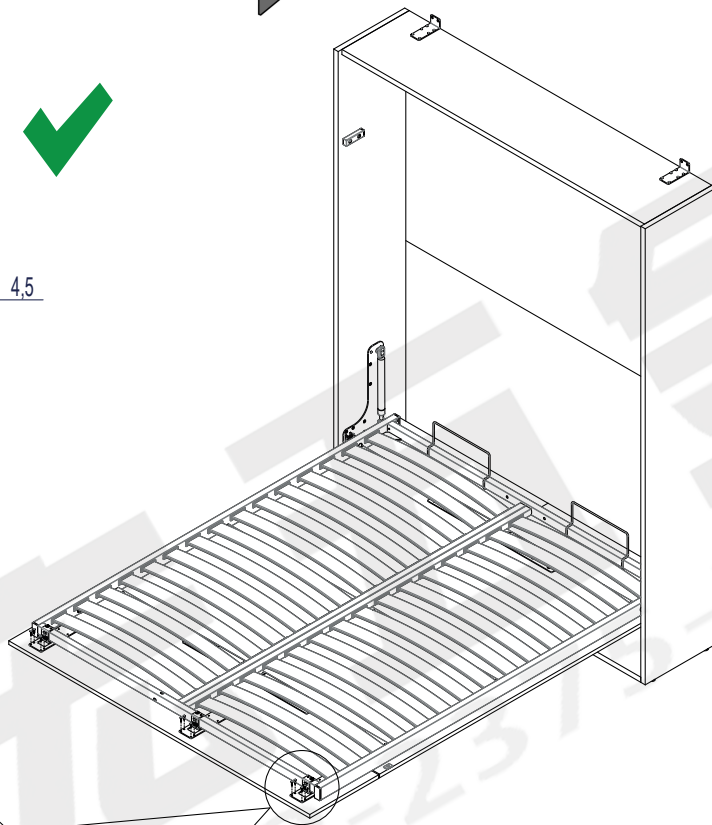
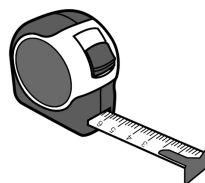
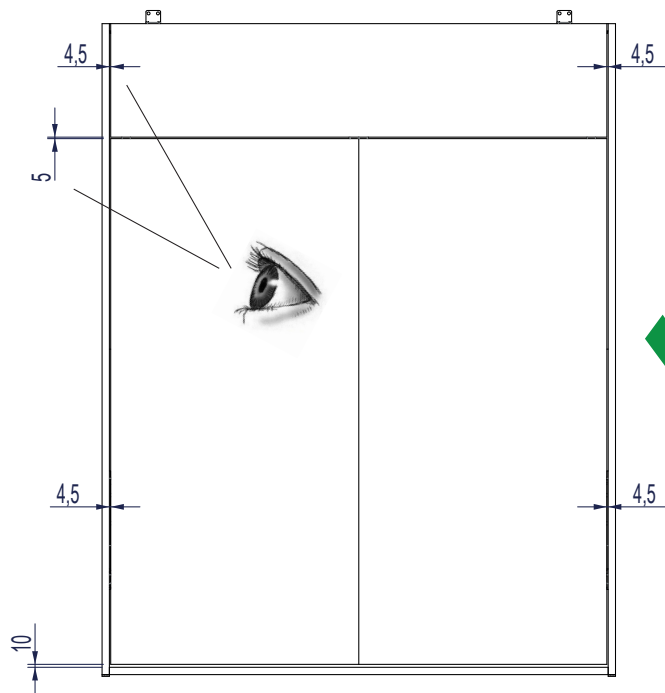

F

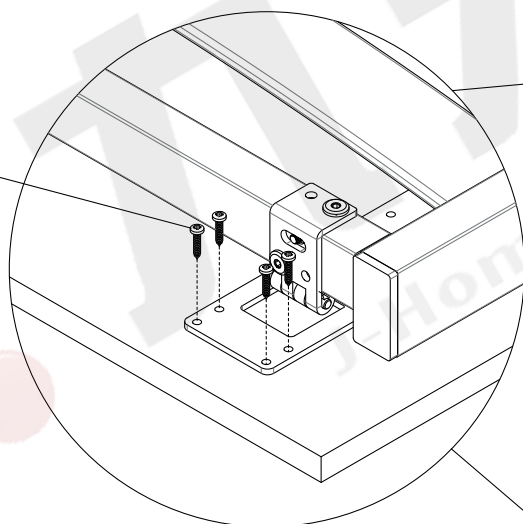

x12

x12

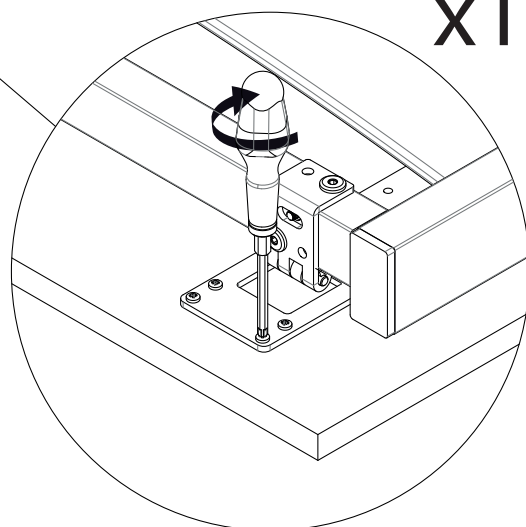

STEP 16

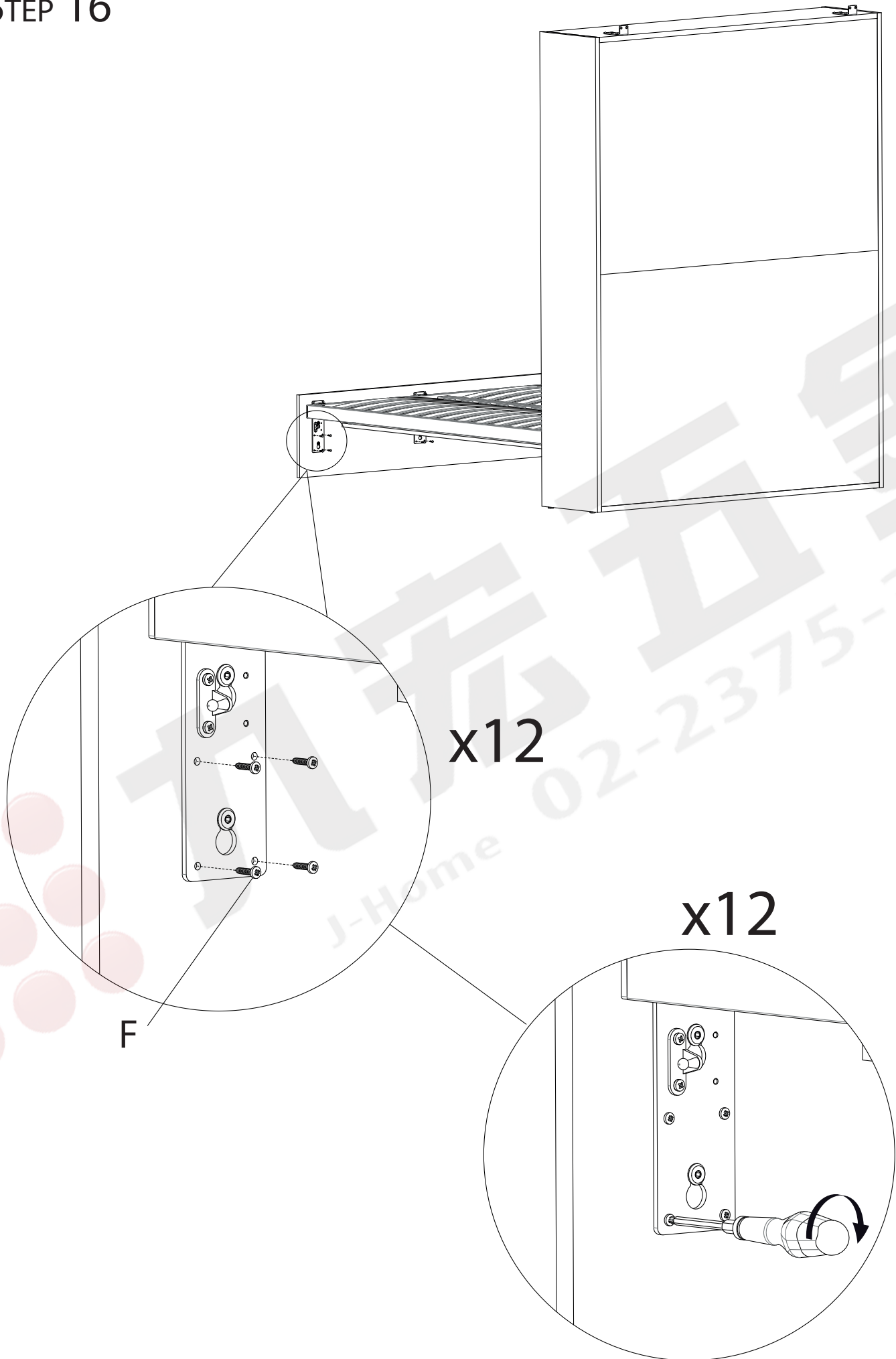

STEP 17

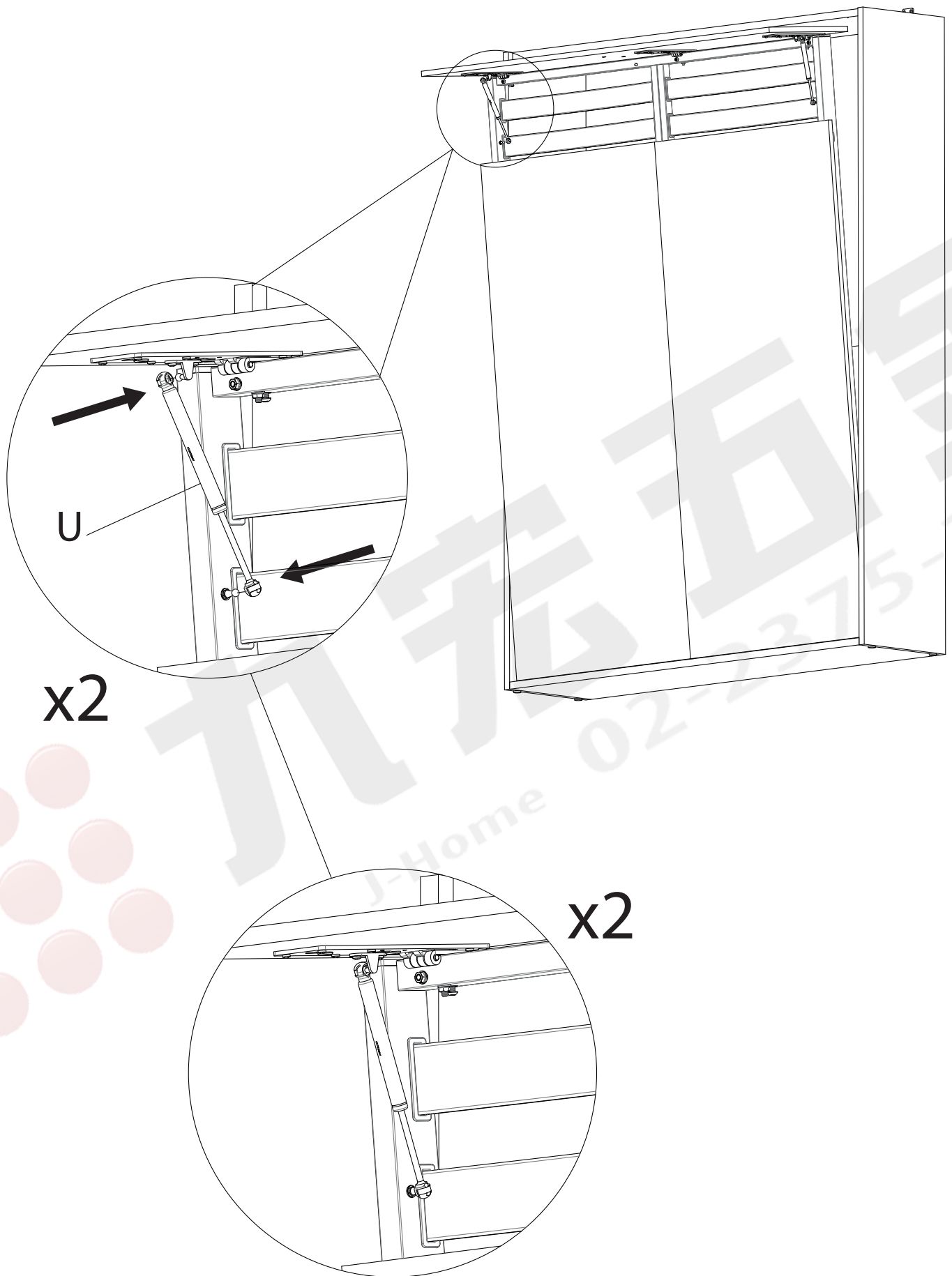

STEP 18

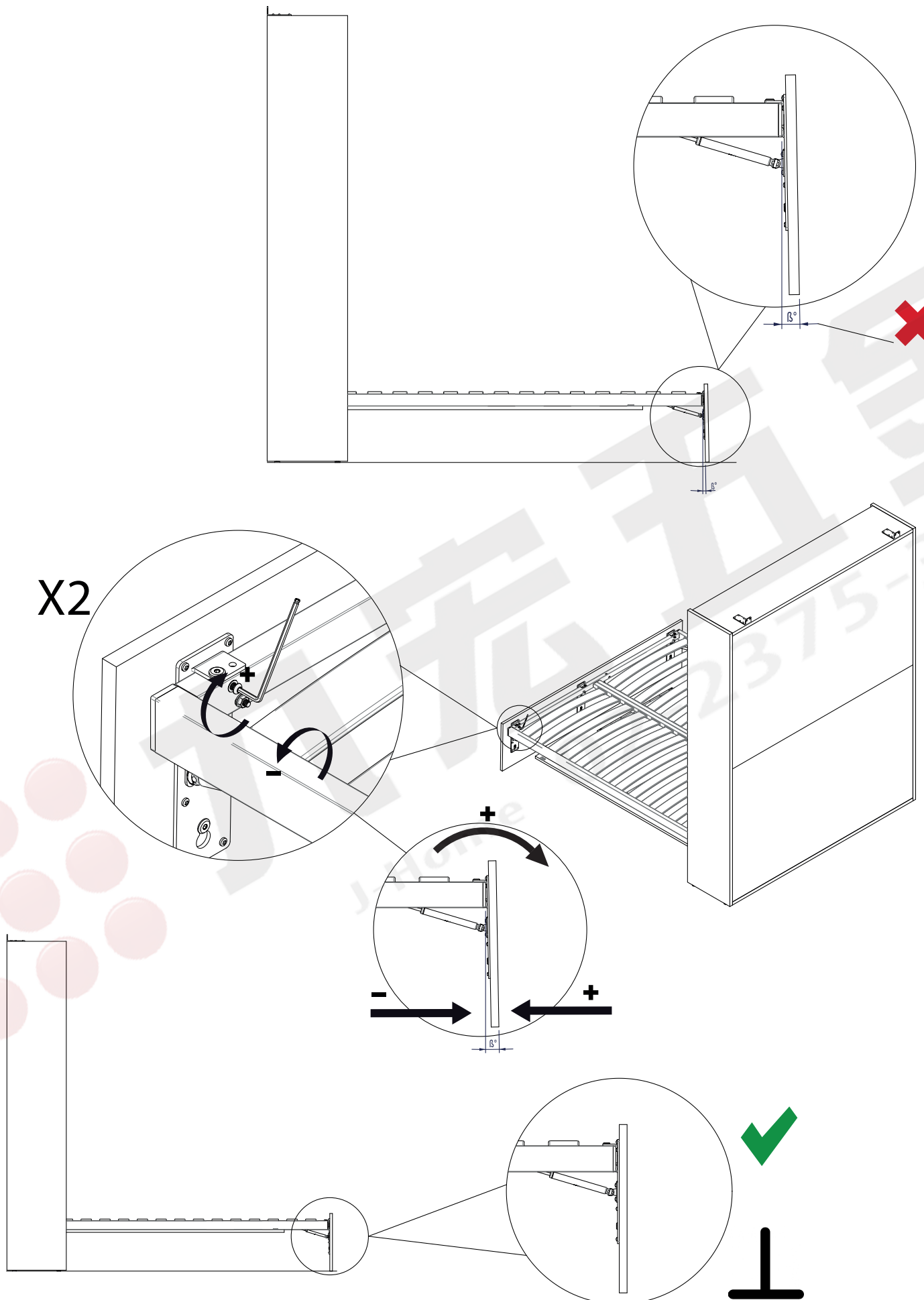

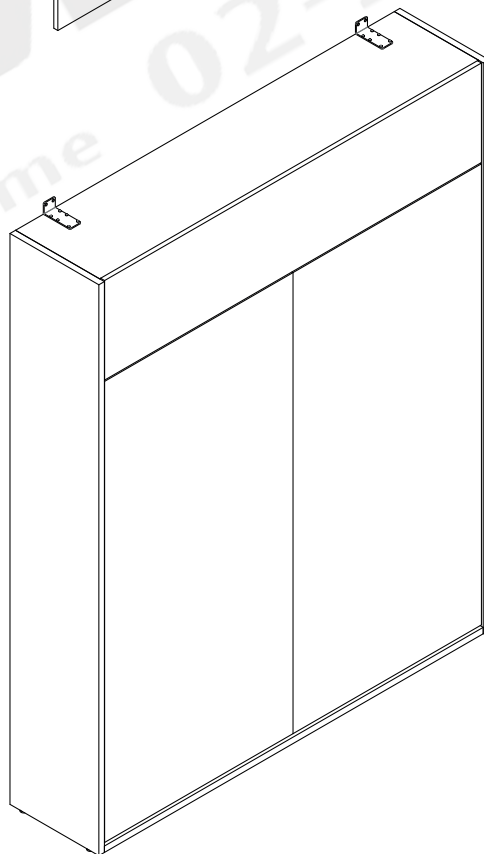
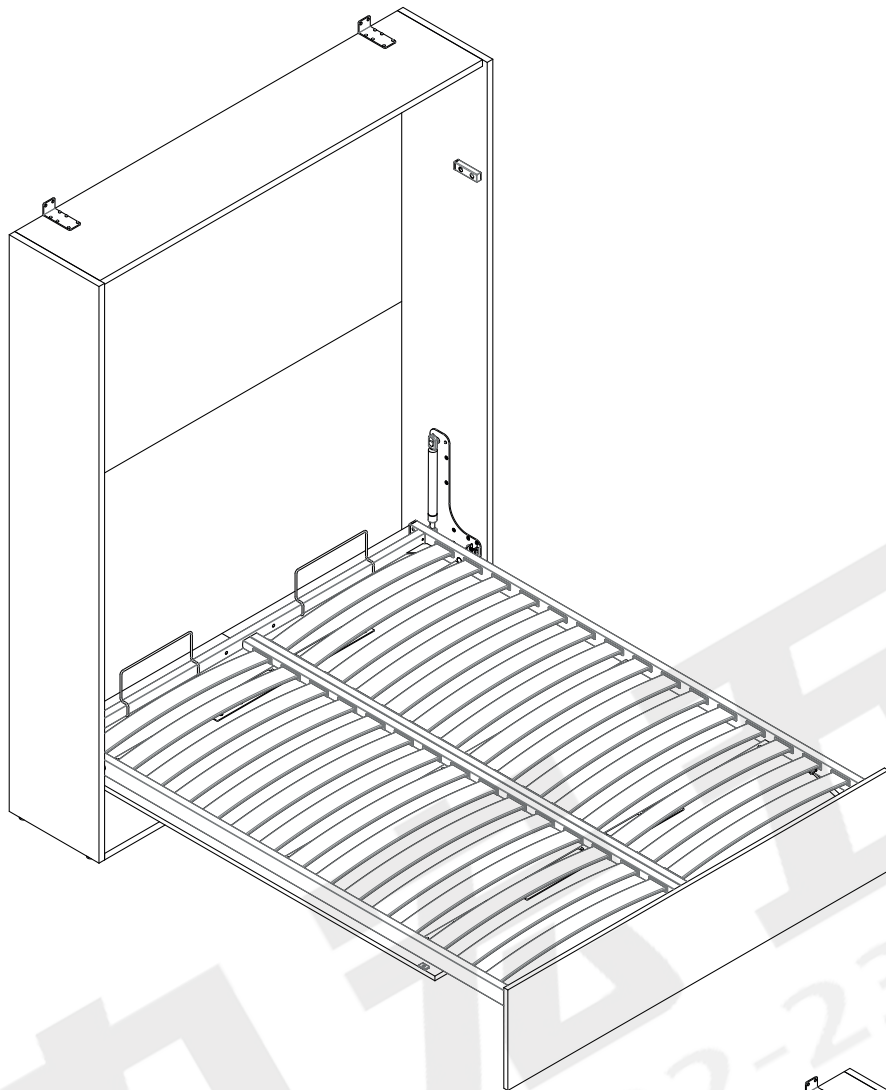

4. MANUTENZIONE-PULIZIA-LUBRIFICAZIONE-SMALTIMENTO

MANUTENZIONE

La manutenzione deve essere fatta su tutte le parti di serraggio degli elementi fissati verificando periodicamente che tutte le viti e i dadi autobloccanti non siano allentati, piegati, danneggiati o mancanti.

Verificare inoltre che gli elementi della rete, del meccanismo di movimentazione, le molle a gas, gli attacchi al contenitore e al muro non siano allentati, piegati, danneggiati o mancanti. la manutenzione deve essere eseguita ogni 60 cicli di apertura/chiusura e/o almeno una volta all' anno.

PULIZIA E LUBRIFICAZIONE

La pulizia delle parti metalliche deve essere eseguita tramite spugna e panni umidi.

Non usare solventi e materiali abrasivi.

La lubrificazione delle parti mobili quali perno di rotazione e cerniere di apertura anta deve essere fatta ogni 60 cicli con del lubrificante.

SMALTIMENTO

I materiali in caso di dismissione devono essere smaltiti nel rispetto della legislazione vigente in materia di rifiuti.



4. MAINTENANCE - CLEANING - LUBRIFICATION - DISPOSAL

MAINTENANCE

Make periodical check of all screwed on parts, including also the steadiness of the wall fixation, by checking that no elements are lose, folded, damaged or missing.

Also check that the elements of the bedspring, the handling mechanism, the gas springs, the attachment to the container and the wall are not loose, bent, damaged, or missing. Maintenance must be performed every 60 opening / closing cycles and / or at least once a year.

CLEANING AND LUBRIFICATION

The cleaning of all metal parts shall be made with a humid sponge or cloth.

Don't use any solvents or abrasive materials.

Lubrication of mobile elements as rotation pivots and door hinges, shall be made every 60 cycles with a lubricant.

DISPOSAL

The different parts shall be disposed in special containers in accordance with the ruling standards.

DO NOT DUMP.

