

Serie 6200

Porte
Doors

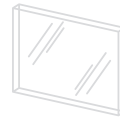

Sistema scorrevole invisibile per porte d'arredo

Invisible sliding system for design doors

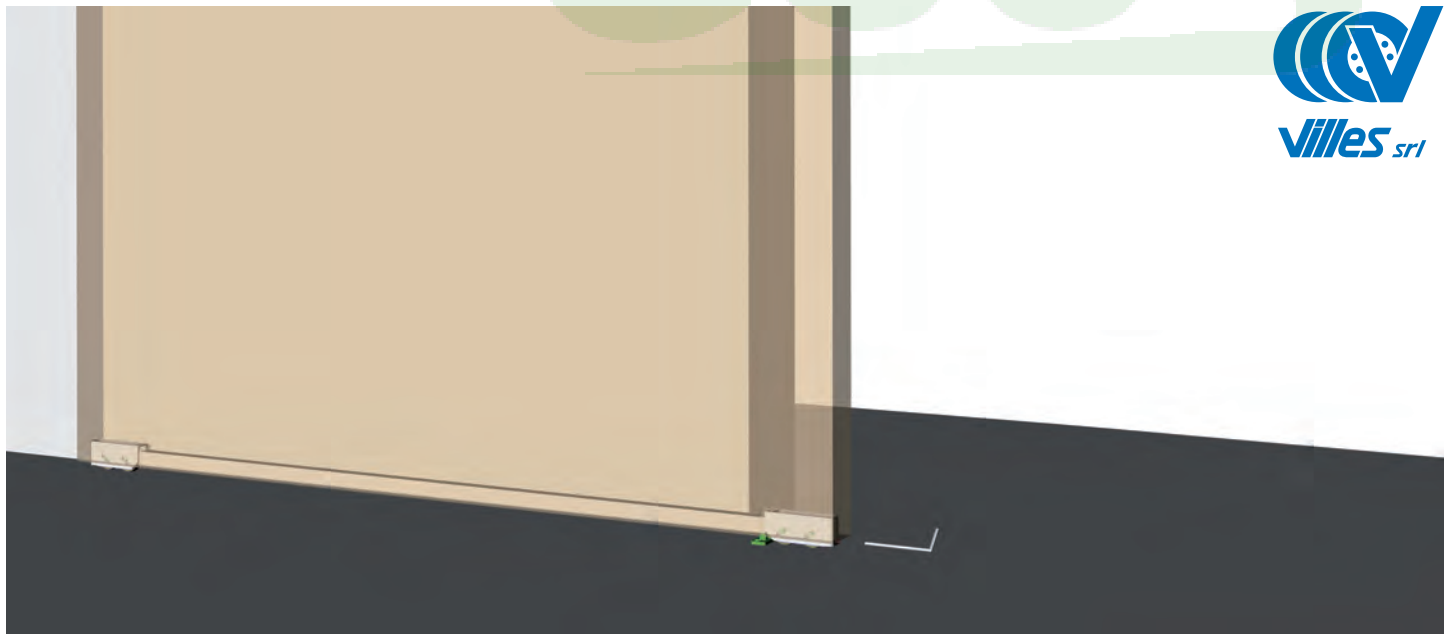
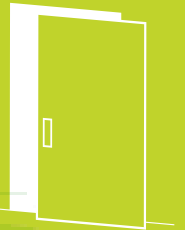

KIT ART. 6212

Kit per porta scorrevole da mm. 626 a mm. 1200
Kit for sliding door to mm. 626 from mm. 1200

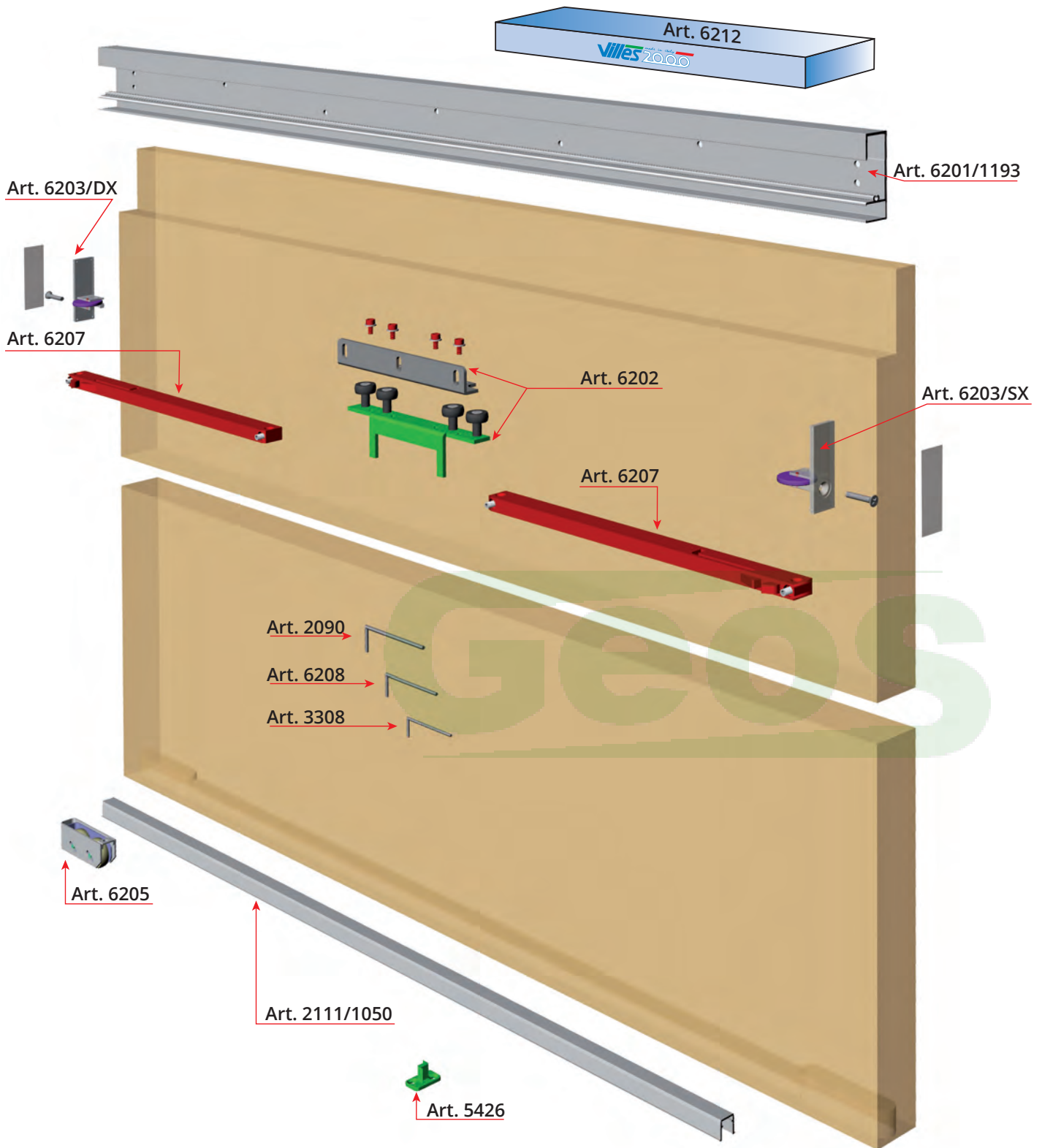

Unica versione "AMBIDESTRA"
Only one version "AMBIDEXTRUS"

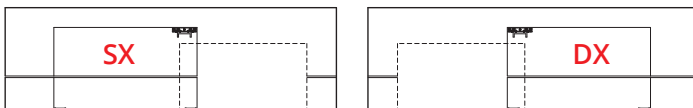

Informazioni tecniche | Technical informations

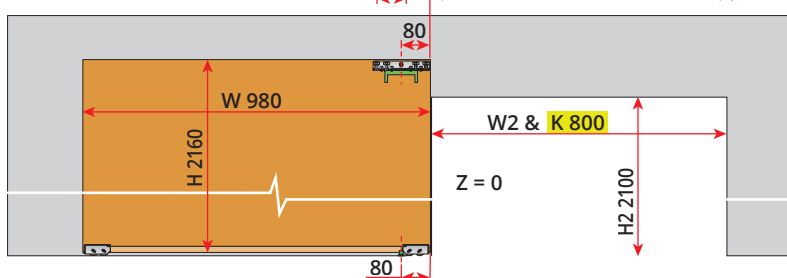
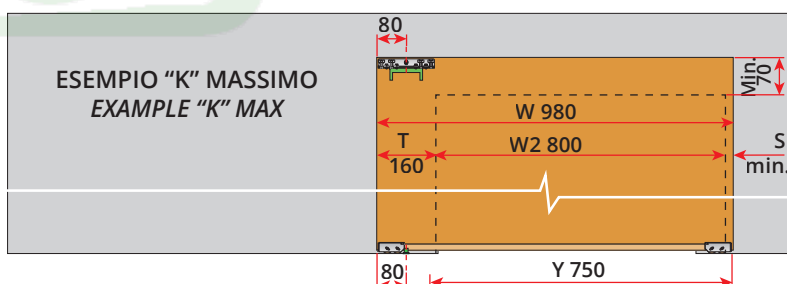
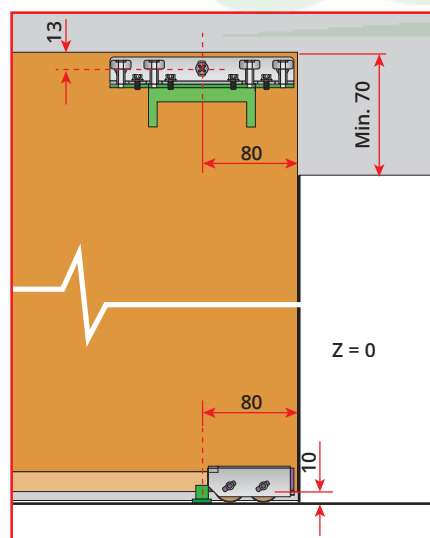
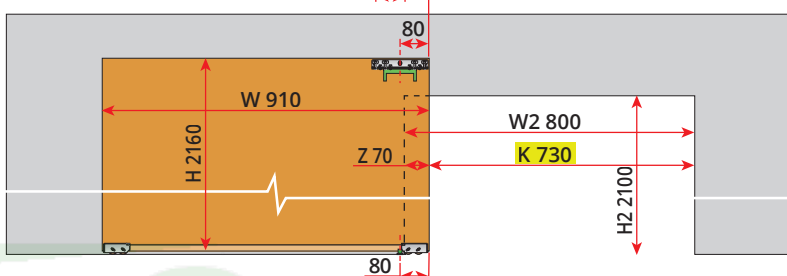
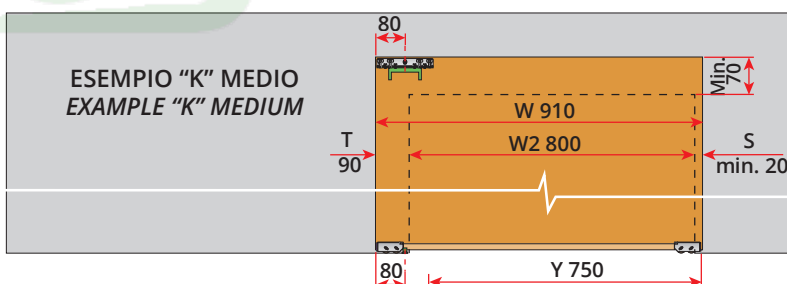
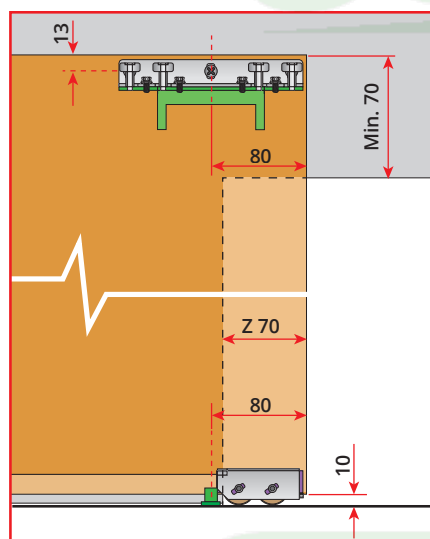
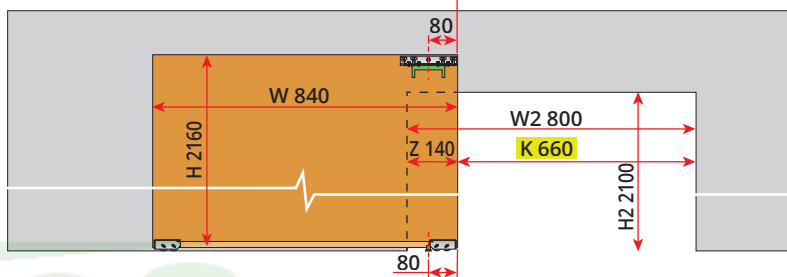
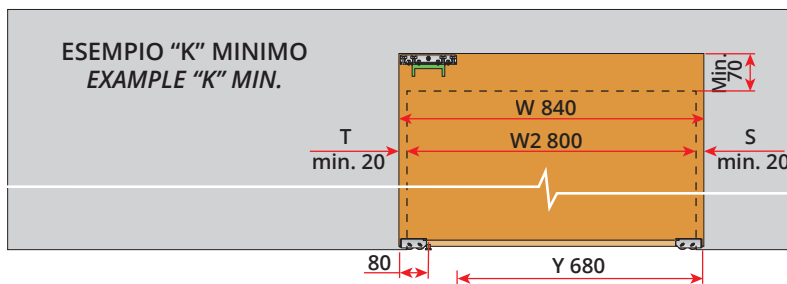
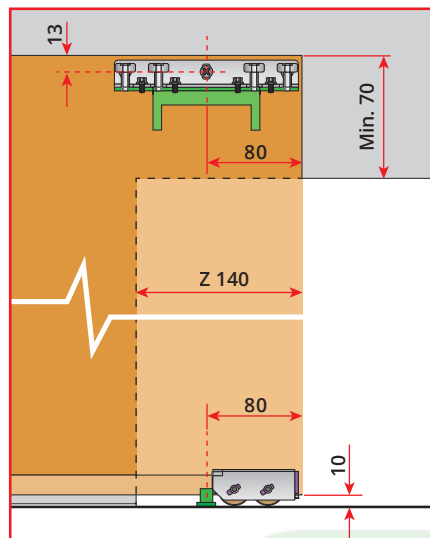



Serie 6200



Calcolo delle proporzioni | Calculation of the proportions

$$\begin{aligned}
 H &= H2 + \text{Min. } 60 \text{ mm.} \\
 Y &= W - \text{Min. } 160 \text{ mm.} \\
 Z &= 0 \div 140 \text{ mm.} \\
 S &= \text{Min. } 20 \text{ mm.} \\
 W &= W2 + \text{Min. } 180^* \text{ mm.} - Z \\
 T &= W - W2 - S \\
 K &= W - 160 \text{ mm.} - S \\
 X &= 80 \text{ mm.}
 \end{aligned}$$

* calcolato con "S" = 20 mm.
calculated with

 = Vano di passaggio / Passage way
 = Porta / Door

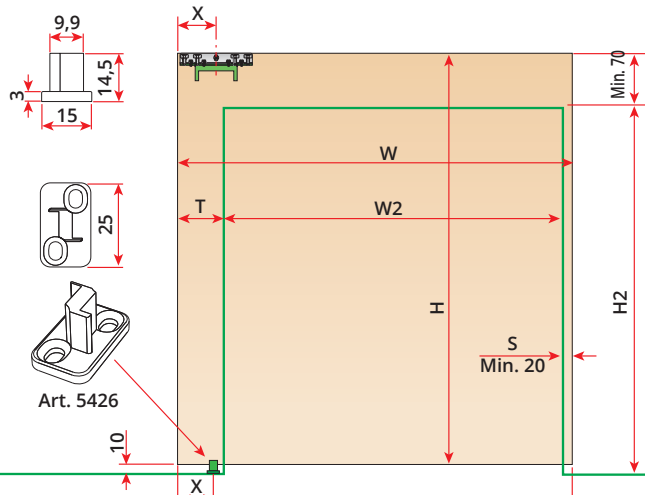

$Y = W - \text{Min. } 160 \text{ mm. (Min.)}$
Corsa / Stroke

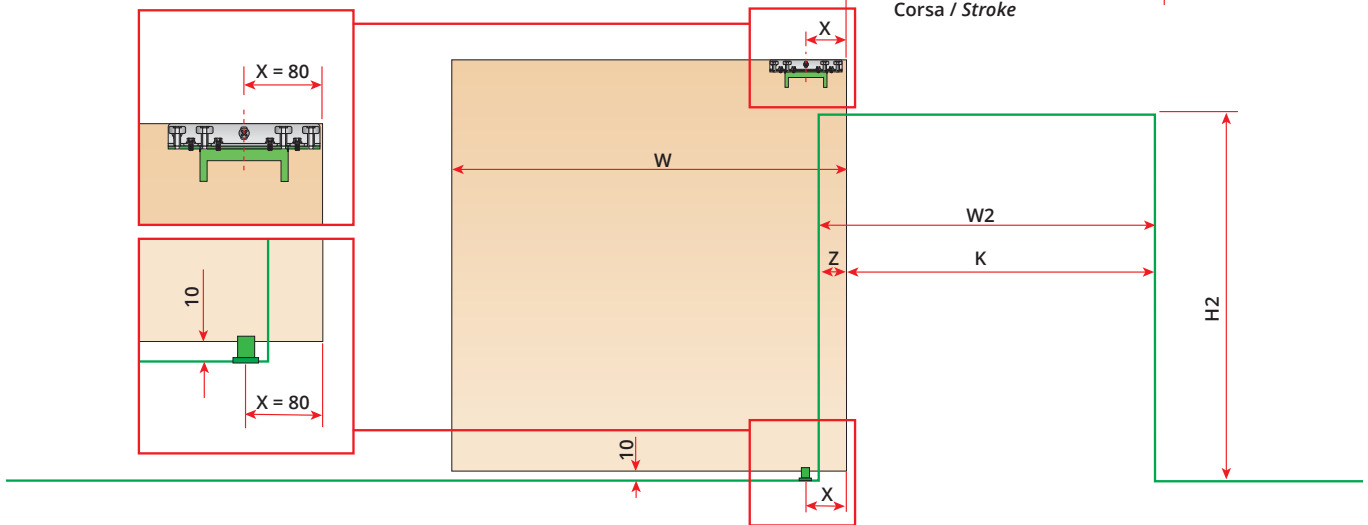

Sezioni e montaggio | Sections and assembling

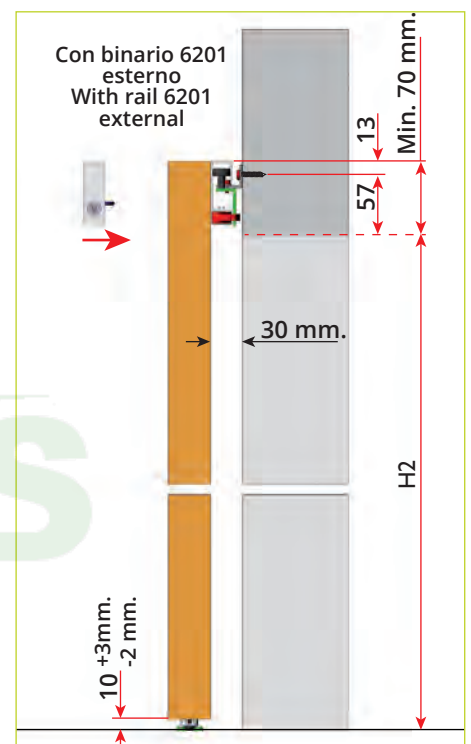
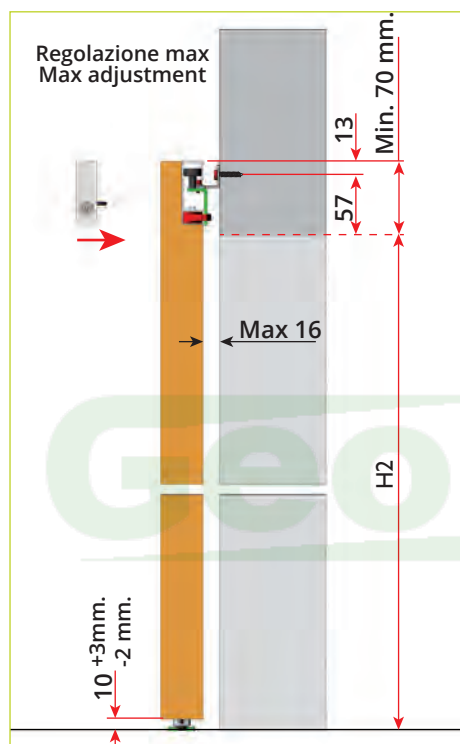
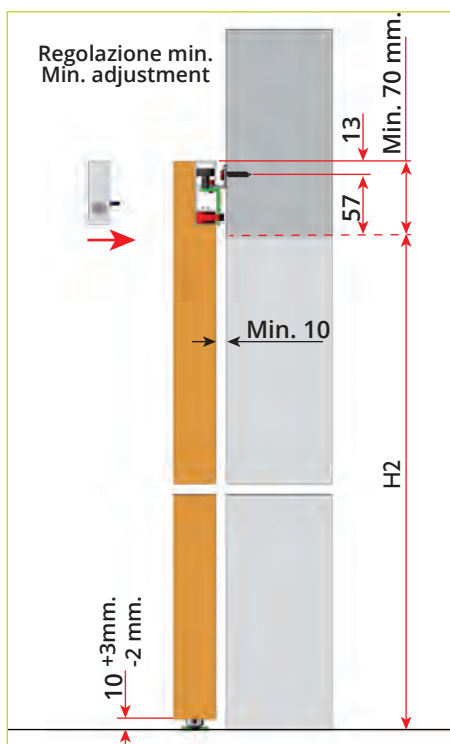

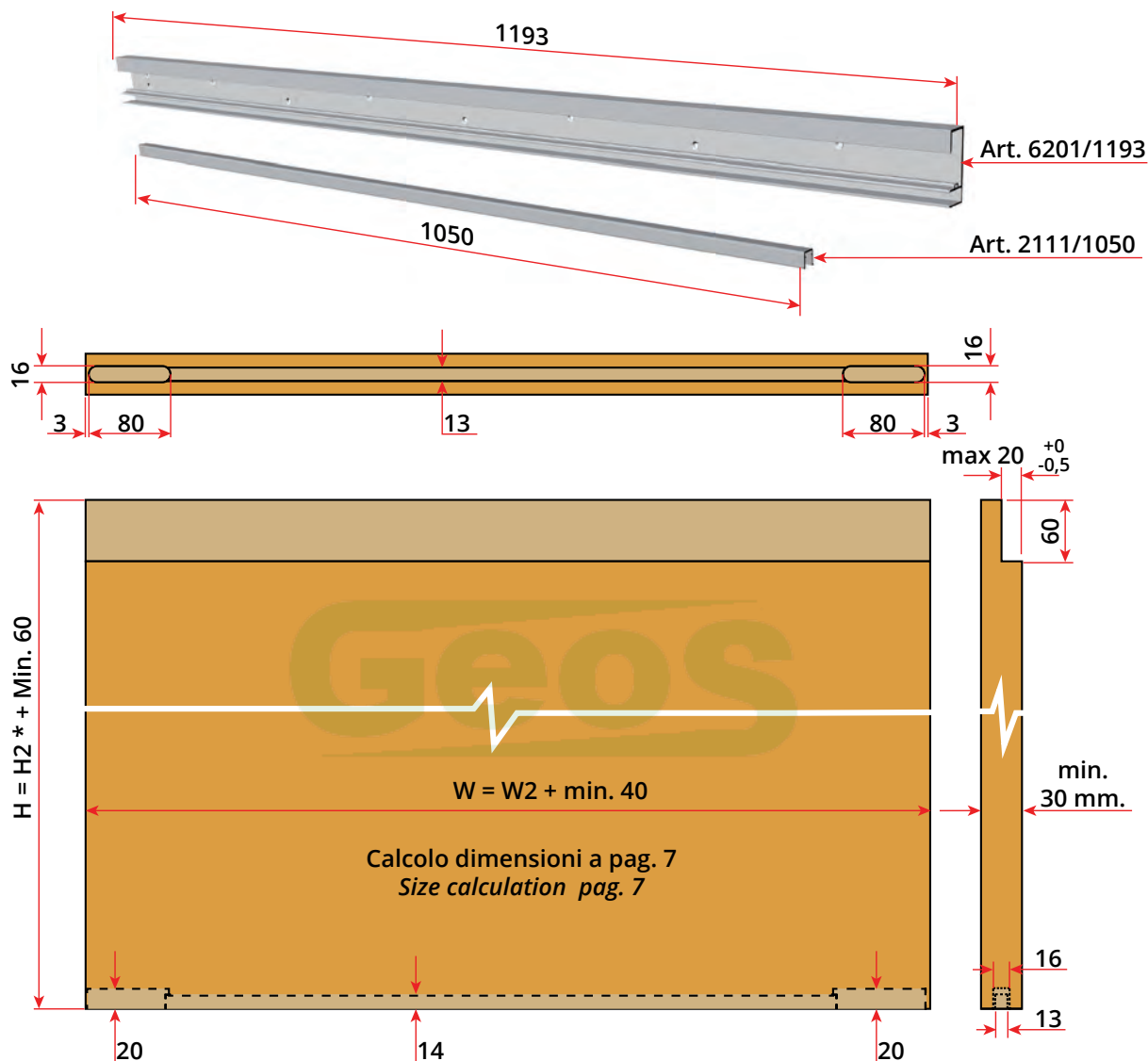

*H2 = Altezza interna del vano | Height of the passage way
 W2 = Larghezza interna del vano | Width of the passage way

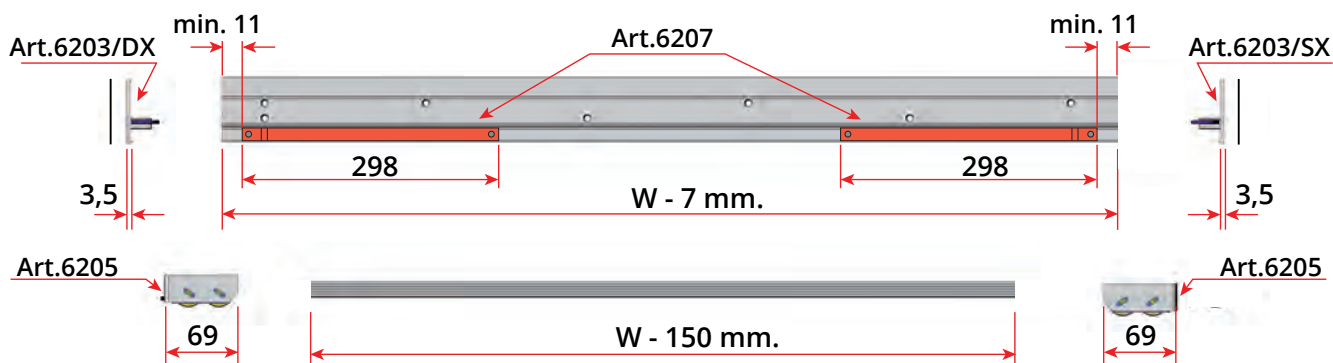
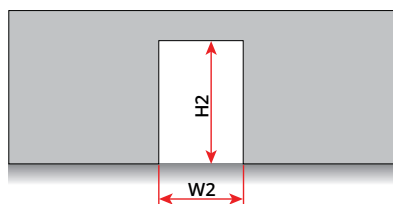

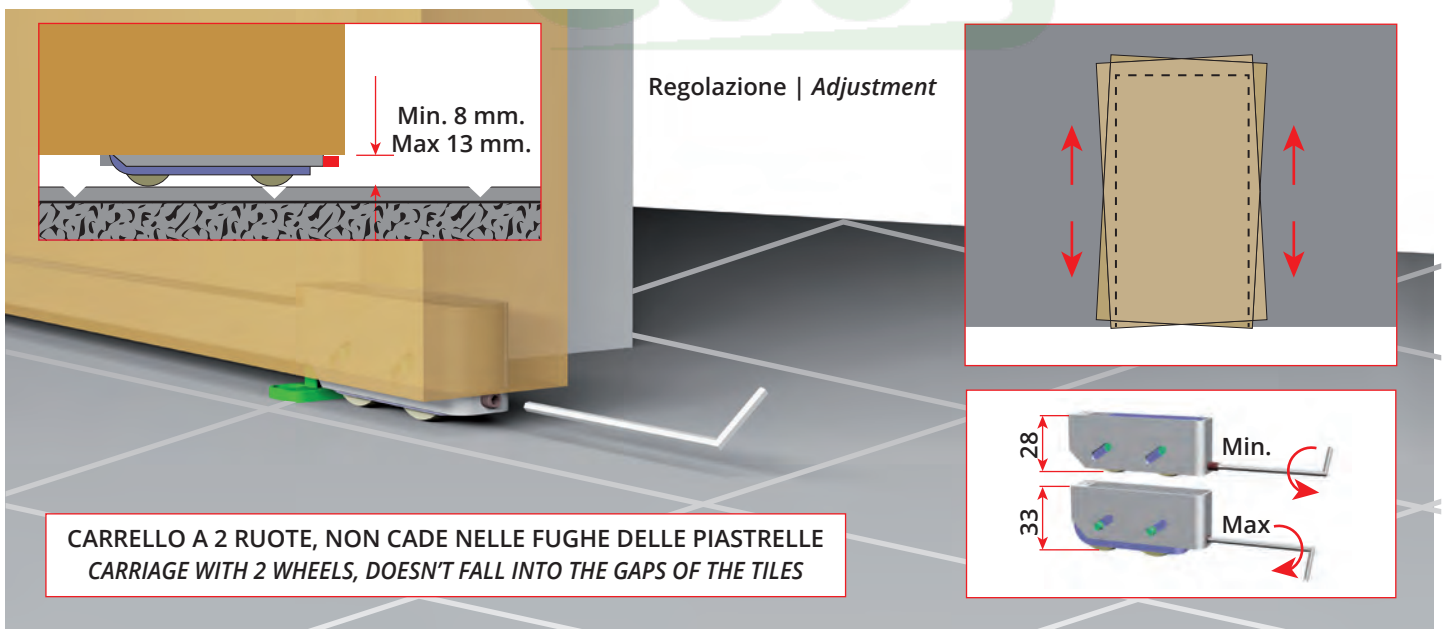
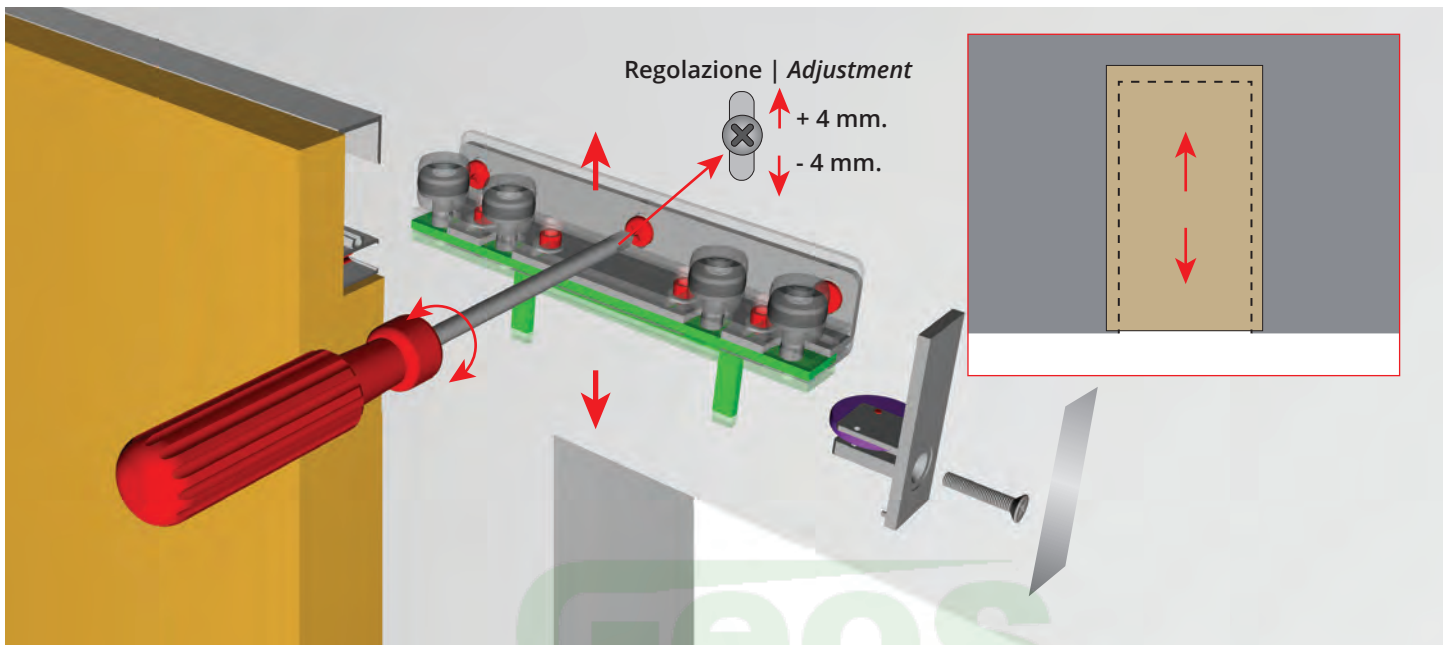
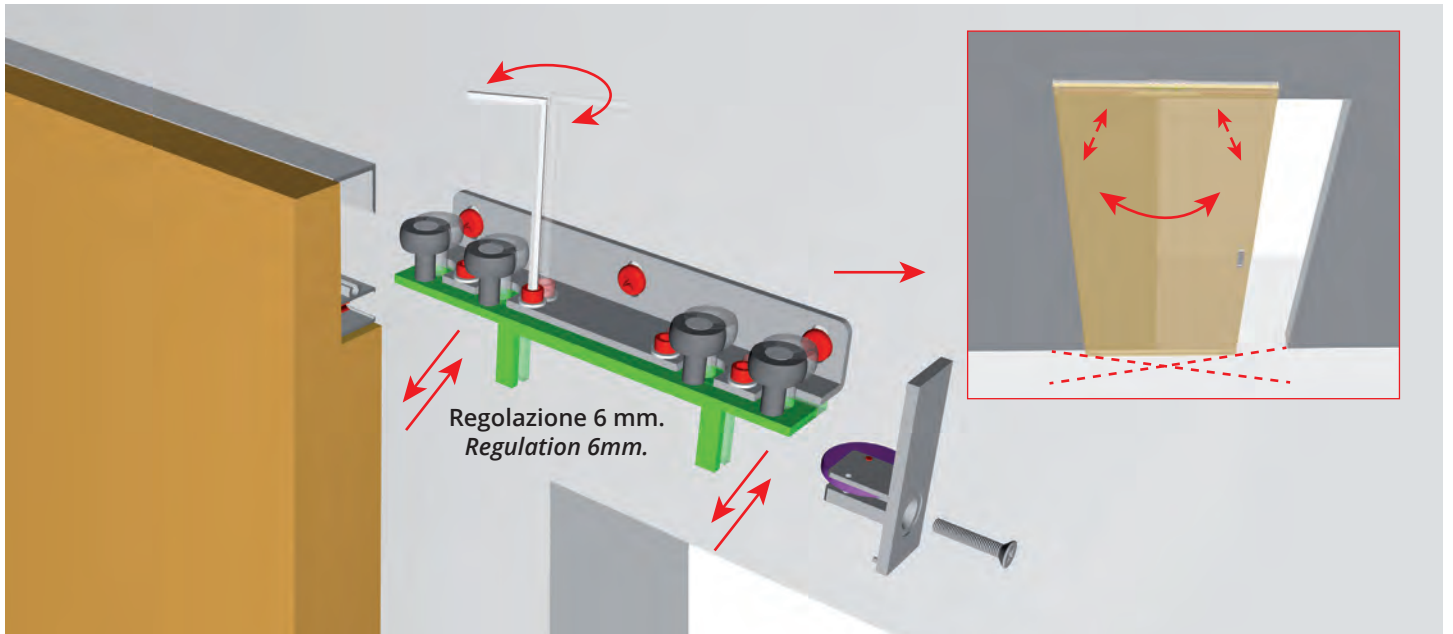

CARRELLO A 2 RUOTE, NON CADE NELLE FUGHE DELLE PIASTRELLE
CARRIAGE WITH 2 WHEELS, DOESN'T FALL INTO THE GAPS OF THE TILES

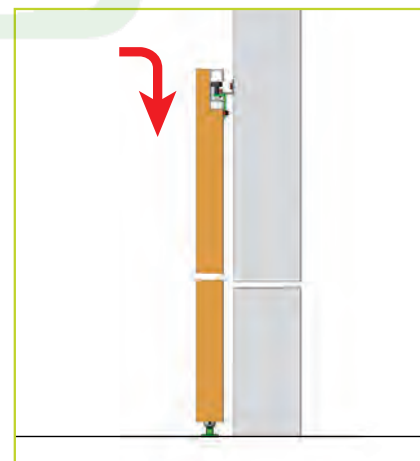
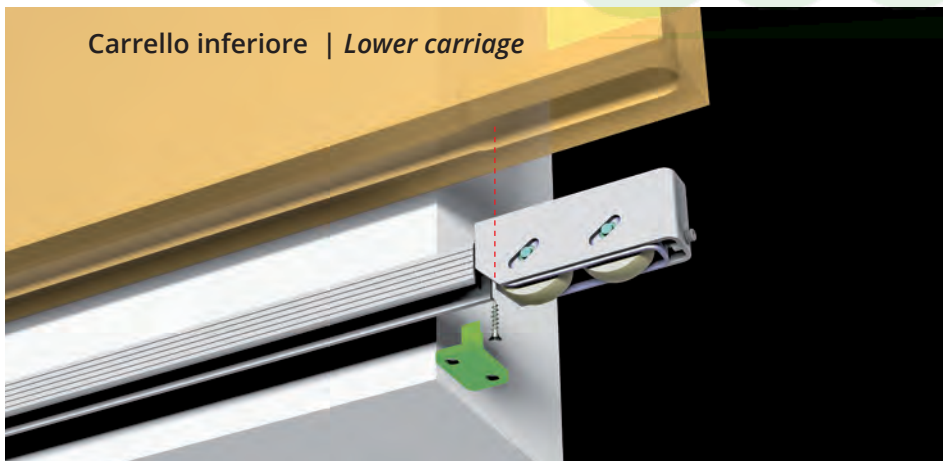
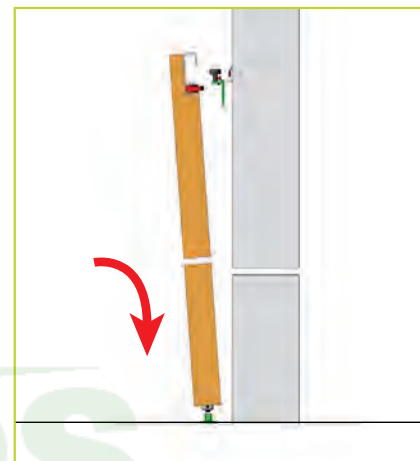
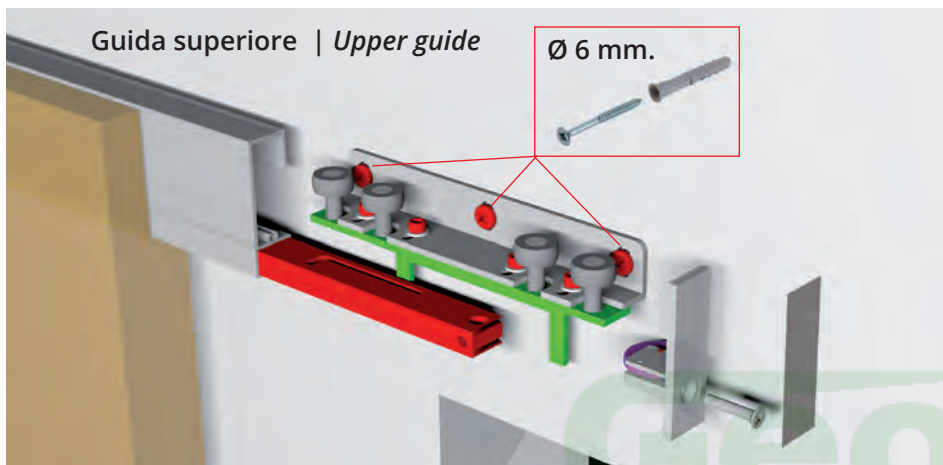

Varianti e optional | Variants and optionals

Proporzioni con binario superiore totalmente incassato, non visibile dai fianchi | Proportion with totally embedded rail, not visible from the sides

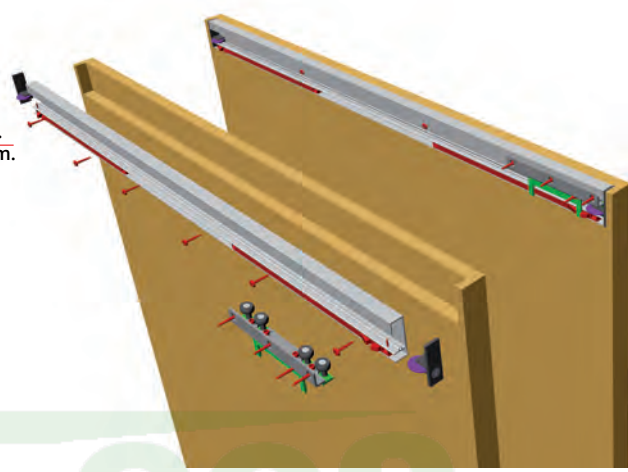
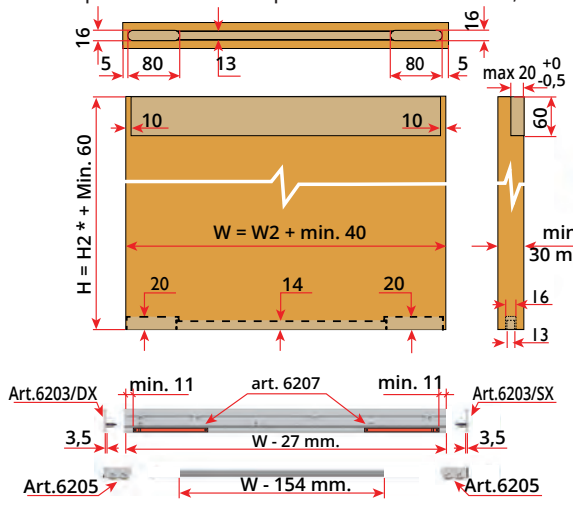

Lista Kit e profili principali | Kits list and main profiles

6201
 2111

Kit 6212

Art. List: 6203 SX | 6203 DX | 6205 x2 | 6207 x2 | 6202 | 5426 | 6201/1193 | 2111/1050 | + chiavi/keys

Serie 6200